

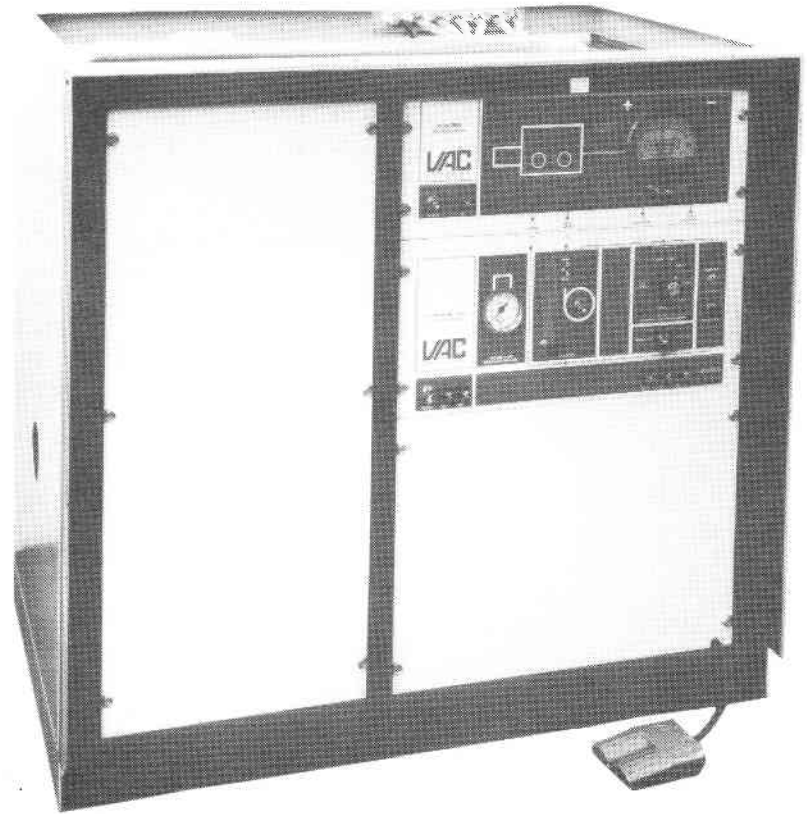

# DRI-TRAIN TECHNICAL MANUAL MODEL M040-2

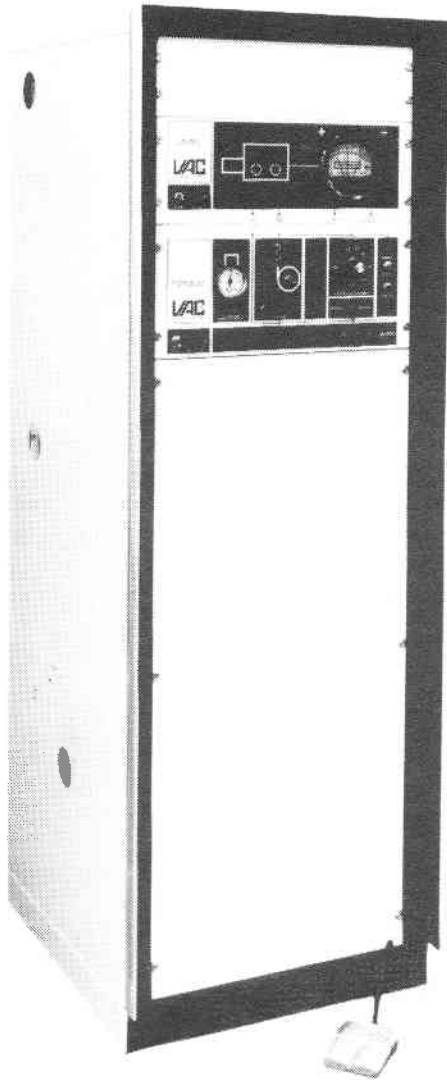

MO-40V AND MO-40H DRI-TRAINS



MO40-2 4/79

---

**VACUUM/ATMOSPHERES COMPANY**

4652 ROSECRANS AVE. • HAWTHORNE, CA 90250  
PHONE (213) 644-0251

---

TABLE OF CONTENTS

<u>SECTION</u>	<u>PARA</u>	<u>TITLE</u>	<u>PAGE</u>
1	1-0	GENERAL . . . . .	1-1
	1-1	APPLICATIONS . . . . .	1-1
	1-2	FUNCTIONAL DESCRIPTION . . . . .	1-1
	1-3	MODEL VARIATIONS . . . . .	1-3
2	2-0	INITIAL INSTALLATION . . . . .	2-1
	2-1	GENERAL . . . . .	2-1
	2-2	ENVIRONMENTAL/SPACE REQUIREMENTS . . . . .	2-1
	2-3	ELECTRICAL REQUIREMENTS . . . . .	2-2
	2-4	TRANSFORMER WIRING OPTIONS . . . . .	2-2
	2-5	230 VOLT OPERATION . . . . .	2-2
	2-6	TRANSFORMER CONNECTIONS . . . . .	2-2
	2-7	UTILITY CONNECTIONS . . . . .	2-5
	2-8	GAS REQUIREMENTS . . . . .	2-5
	2-9	COMPRESSED-AIR . . . . .	2-6
	2-10	VENTING . . . . .	2-6
	2-11	WATER REQUIREMENTS . . . . .	2-6
	2-12	ATMOSPHERIC MONITORING . . . . .	2-7
	2-13	INERT GAS PLUMBING . . . . .	2-7
3	3-0	INITIAL SETUP . . . . .	3-1
	3-1	ELECTRICAL CHECKOUT . . . . .	3-1
	3-2	INITIAL CONDITIONS . . . . .	3-1
	3-3	PROCEDURE FOR ELECTRICAL CHECKOUT . . . . .	3-2
	3-4	ESTABLISHING AN INERT ATMOSPHERE . . . . .	3-10
	3-5	PURGING THE SYSTEM . . . . .	3-10
	3-6	NON-DRI-LAB SYSTEMS . . . . .	3-11
	3-7	PRESSURE CONTROL TESTS . . . . .	3-11
	3-8	PROCEDURE-PRESSURE TESTING . . . . .	3-12
	3-9	INITIAL REGENERATION . . . . .	3-14
	3-10	REGENERATION SEQUENCE-SIMPLIFIED . . . . .	3-14
4	4-0	OPERATING INSTRUCTIONS . . . . .	4-1
	4-1	GENERAL . . . . .	4-1
	4-2	OPERATING MODE . . . . .	4-2
	4-3	SYSTEM TURN-ON . . . . .	4-2
	4-4	WAIT-TIME AFTER TURN-ON . . . . .	4-3
	4-5	CONTROLS AND INDICATORS . . . . .	4-4
	4-6	DAILY OPERATIONS . . . . .	4-4
	4-7	MONITORING UTILITIES . . . . .	4-7
	4-8	PHOTOHELIC OPERATION . . . . .	4-8

TABLE OF CONTENTS (Continued)

<u>SECTION</u>	<u>PARA</u>	<u>TITLE</u>	<u>PAGE</u>
	4-9	FOOT SWITCH OPERATION . . . . .	4-8
	4-10	REGENERATION . . . . .	4-9
	4-11	REGENERATION PERIOD . . . . .	4-9
	4-12	INSTRUMENTATION . . . . .	4-9
	4-13	REGENERATION OPERATION . . . . .	4-10
	4-14	REPLACING THE PURIFIER CHEMICALS . . . . .	4-10
	4-15	SYSTEM PUMP-DOWN . . . . .	4-11
5	5-0	THEORY OF OPERATION . . . . .	5-1
	5-1	GENERAL . . . . .	5-1
	5-2	PRESSURE CONTROL . . . . .	5-2
	5-3	THEORY . . . . .	5-2
	5-4	PHOTOHELIC . . . . .	5-6
	5-5	THEORY . . . . .	5-6
	5-6	PURIFIER . . . . .	5-7
	5-7	THEORY . . . . .	5-7
	5-8	OXYGEN REMOVAL . . . . .	5-8
	5-9	WATER REMOVAL . . . . .	5-8
	5-10	PROPERTIES OF THE GAS RECIRCULATION SYSTEM . . . . .	5-9
	5-11	SYSTEM REQUIREMENTS . . . . .	5-9
	5-12	ESTIMATING THE LEAKAGE RATES . . . . .	5-9
	5-13	CONTAMINATION . . . . .	5-10
	5-14	CIRCULATION RATE . . . . .	5-10
	5-15	VOLUME . . . . .	5-10
	5-16	RECOVERY TIME . . . . .	5-10
	5-17	REGENERATION TIME . . . . .	5-11
	5-18	LEVELS OF PURITY ATTAINABLE . . . . .	5-11
	5-19	PURIFIER CONSTRUCTION . . . . .	5-11
	5-20	CHEMICALS . . . . .	5-11
	5-21	REGENERATION . . . . .	5-12
	5-22	THEORY . . . . .	5-12
	5-23	REGENERATION/FORMING GAS . . . . .	5-12
	5-24	REGENERATION - PRELIMINARY CONDITIONS . . . . .	5-13
	5-25	REGENERATION OPERATION SEQUENCE - GENERAL . . . . .	5-14
	5-26	GENERAL . . . . .	5-14
	5-27	AUTOMATIC SEQUENCE . . . . .	5-14
	5-28	DETAILS . . . . .	5-15
	5-29	TIMER CAMS . . . . .	5-15
	5-30	CAM-1 . . . . .	5-16
	5-31	CAM-2 . . . . .	5-16
	5-32	CAM-3 . . . . .	5-17
	5-33	CAM-4 . . . . .	5-17
	5-34	CAM-5 . . . . .	5-18
	5-35	TERMINATION . . . . .	5-18
	5-36	CIRCULATOR . . . . .	5-18
	5-37	VACUUM PUMP . . . . .	5-18

## TABLE OF CONTENTS (Continued)

<u>SECTION</u>	<u>PARA</u>	<u>TITLE</u>	<u>PAGE</u>
6			
	6-0	TROUBLESHOOTING . . . . .	6-1
	6-1	GENERAL . . . . .	6-1
	6-2	VACUUM PUMP . . . . .	6-1
	6-3	CIRCULATOR . . . . .	6-1
	6-4	PHOTOHELIC . . . . .	6-2
	6-5	SOLENOID VALVES . . . . .	6-3
	6-6	AIR-OPERATED VALVES . . . . .	6-11
	6-7	REGENERATION TIMER . . . . .	6-12
	6-8	PRESSURE PROBLEMS - GENERAL . . . . .	6-13
	6-9	PROBLEM CATEGORIES . . . . .	6-13
	6-10	CATEGORY (A-1) . . . . .	6-15
	6-11	CATEGORY (A-2) . . . . .	6-15
	6-12	CATEGORY (B-1) . . . . .	6-16
	6-13	CATEGORY (B-2) . . . . .	6-16
	6-14	HELIUM LEAK TESTING . . . . .	6-17
7			
	7-0	MAINTENANCE . . . . .	7-1
	7-1	GENERAL . . . . .	7-1
	7-2	PERIODIC MAINTENANCE INSPECTIONS . . . . .	7-1
	7-3	NON-SCHEDULED MAINTENANCE . . . . .	7-1
	7-4	VACUUM PUMP . . . . .	7-2
	7-5	CIRCULATION FILTERS . . . . .	7-2
	7-6	HEAT EXCHANGER . . . . .	7-2
	7-7	LINES AND CONNECTIONS . . . . .	7-3
	7-8	AIR VALVES (V12A, V13A, V12B, V13B) . . . . .	7-3
	7-9	LEAK TESTING . . . . .	7-3
	7-10	LEAK TESTING - HELIUM SNIFFER . . . . .	7-4
	7-11	LEAK TESTING - BUBBLE AND PRESSURE . . . . .	7-4
	7-12	STEPS . . . . .	7-5
	7-13	CHEMICAL CHARGE - REPLACEMENT . . . . .	7-6
	7-14	REPLACEMENT . . . . .	7-6
	7-15	PROCEDURE . . . . .	7-6
8			
	8-0	PARTS . . . . .	8-1
	8-1	REPLACEMENT POLICY . . . . .	8-1
	8-2	REWORKED PARTS . . . . .	8-1
	8-3	CIRCULATOR . . . . .	8-1
	8-4	VACUUM PUMP . . . . .	8-1
	8-5	PHOTOHELIC . . . . .	8-1
	8-6	ORDERING PROCEDURES . . . . .	8-2
	8-7	PARTS LIST AND PHOTOS . . . . .	8-2
	8-8	GENERAL . . . . .	8-2

INDEX

LIST OF ILLUSTRATIONS

<u>FIGURE</u>	<u>TITLE</u>	<u>PAGE</u>
1-1	DRI-TRAIN/DRI-LAB Simplified System Diagram . . . . .	1-6
1-2	MO40-2H Front View . . . . .	1-7
1-3	MO40-2H Front View - Panels Open . . . . .	1-7
1-4	MO40-2H Rear View . . . . .	1-8
1-5	MO40-2V Front View . . . . .	1-9
1-6	MO40-2V Front View - Panels Open . . . . .	1-10
1-7	MO40-2V Rear View . . . . .	1-11
2-1	Utility Connection Strip . . . . .	2-8
3-1	DRI-TRAIN Control Panel - Front View . . . . .	3-16
3-2	DRI-TRAIN Control Panel - Rear View . . . . .	3-16
3-3	Pedatrol Panel - Front View . . . . .	3-17
3-4	Pedatrol Panel - Rear View . . . . .	3-17
3-5	Photohelic - Front View . . . . .	3-18
3-6	Photohelic - Rear View . . . . .	3-18
3-7	Footswitch - Pedatrol . . . . .	3-19
4-1	Oxygen Recovery Rates . . . . .	4-3
5-1	MO40-2 Gas Flow Diagram . . . . .	5-20
5-2	MO40-2 Schematic Diagram . . . . .	5-21
5-3	MO40 Purifier Cross Section . . . . .	5-22
5-4	Regeneration Timing Diagram . . . . .	5-23
6-1	MO40-2 Simplified System Diagram . . . . .	6-22
6-2	Regeneration Timer - Upper View . . . . .	6-23
6-3	Regeneration Timer - Side View . . . . .	6-24
8-1	MO40-2H Front View . . . . .	8-5
8-2	MO40-2H Front View - Panels Open . . . . .	8-5
8-3	MO40-2H Rear View . . . . .	8-6
8-4	MO40-2V Front View . . . . .	8-7
8-5	MO40-2V Front View - Panels Open . . . . .	8-7
8-6	MO40-2V Rear View . . . . .	8-8
8-7	DRI-TRAIN Control Panel - Front View . . . . .	8-9
8-8	DRI-TRAIN Control Panel - Rear View . . . . .	8-9
8-9	Pedatrol Panel - Front View . . . . .	8-10
8-10	Pedatrol Panel - Rear View . . . . .	8-10
8-11	Electrical Sub-Assembly Panel . . . . .	8-11
8-12	Foot Switch - Pedatrol . . . . .	8-12
8-13	Vacuum Pump - Leybold Heraeus . . . . .	8-13
8-14	Vacuum Pump - Sargent Welch . . . . .	8-13
8-15	Pneumatic Actuator and Valve Assembly . . . . .	8-14
8-16	Circulator . . . . .	8-15

LIST OF TABLES

<u>TABLE</u>	<u>TITLE</u>	<u>PAGE</u>
1-1	M040-2 Specifications . . . . .	1-4
1-2	M040-2 Purifier Dimensions . . . . .	1-5
2-1	Utility Requirements . . . . .	2-3
3-1	Electrical Checkout Procedure . . . . .	3-4
4-1	List of Controls and Indicators . . . . .	4-5
5-1	Major DRI-TRAIN Components . . . . .	5-3
6-1	Solenoid Valve Failure Indications . . . . .	6-5
8-1	Parts List M040-2 . . . . .	8-3

## INTRODUCTION

This manual is presented to provide the users of Vacuum Atmospheres Company's DRI-TRAIN systems with data pertinent to the installation, operation and maintenance of the M040-2.

Additional information is provided concerning the applications, theory of operation, and parts.

A table of contents and a subject index (at the back of the manual) provide for ready accessibility of all data.

Illustrations, drawings, and photos add to the overall clarity and accuracy of the text herein.

Additional requirement for information relative to any VAC system should be referred to:

Vacuum Atmospheres Company  
4652 West Rosecrans Avenue  
Hawthorne, CA 90250  
(213) 644-0251

## W A R R A N T Y

This unit is warranted to be free from defect, in factory material and workmanship for a period of one year from date of purchase, subject to normal wear and freedom from undue abuse during handling and operation. Components, such as pumps and motors purchased from others and included in the unit, are subject to warranties as offered by the manufacturer of said components.

VAC affirms that it will repair the part, or furnish a replacement part (F.O.B. its factory) without charge, provided said part:

- Was found to have been defective at the time it was received.
- Is returned to the factory (charges pre-paid).

This warranty applies only to new equipment, which after shipment from the factory has not been altered, changed, or treated in any manner whatsoever, and does not extend to trade accessories operated with VAC's own equipment.

This is the only warranty expressed, implied, or statutory upon which said equipment is sold. All other damages and warranties statutory and otherwise, being hereby waived by purchaser.



1-0 General1-1 APPLICATIONS

The purpose of the DRI-TRAIN system is to provide a moisture and oxygen-free atmosphere inside a glove-box by recirculating an inert gas. This permits handling of materials sensitive to moisture and oxygen contamination. The gas circulated by the DRI-TRAIN may be argon or helium, but nitrogen (although not totally inert) may also be used.

1-2 FUNCTIONAL DESCRIPTION (See Figure 1-1)

The DRI-TRAIN produces a moisture and oxygen-free environment in a glove-box, (such as the DRI-LAB by Vacuum Atmospheres Company). This is done by replacing all the air from the box with dry, inert gas. This inert gas is then continuously cycled through a purifier which removes moisture and oxygen contamination from any source, such as:

- Diffusion through the rubber gloves.
- Insertion of contaminated parts into the glove-box.
- Use of make-up gas which is not completely free of moisture or oxygen.

Since the glove-box is a hermetically sealed system, slight changes in pressure caused by temperature variations will readily affect the pressure in the system and hence the position of the gloves.

The DRI-TRAIN system provides manual and automatic controls for adjusting the position of the gloves. This is done by providing small positive or negative pressure variations as needed. These pressure variations are generated automatically by the Pedatrol or manually by depressing a foot switch.

The DRI-TRAIN is capable of attaining and maintaining an inert atmosphere with less than one-part-per-million, by volume, moisture and oxygen in a hermetically sealed system of an appropriate volume, and is constructed of appropriate materials.

The DRI-TRAIN/DRI-LAB system is a completely sealed, recirculating system. When the desired atmosphere is obtained, the gas is continuously recirculated. This recirculating gas continually undergoes moisture and oxygen removal, and is automatically replenished as necessary.

A vacuum pump is employed as the source for pressure reduction in the glove-box, and is used to evacuate the purifier during the regeneration cycle. In some applications this pump may also be used to evacuate the glove-box ante-chamber.

1-3 MODEL VARIATIONS

The only two major variations in the M040 units involve the physical packaging and the number of purifier beds incorporated in the system.

The M040-H systems are housed in horizontal cabinets, (See Figures 1-2, 1-3, and 1-4). The M040-V systems are built into vertical rack cabinets (Figures 1-5, 1-6, and 1-7).

The pneumatic/electrical functions of the M040-2H and M040-2V are identical, and the purifiers of these models are physically and functionally the same.

Table 1-1 indicates the purifier functional specifications, and Table 1-2 contains the component's dimensions.

The M040-1V and -1H models have one gas purifier per unit.

Table 1-1. M040-2 Specifications

MINIMUM FLOW RATES:	Argon 40 cfm, nitrogen 43 cfm, helium 50 cfm.
PIPING:	1-1/2" copper/stainless. Connections are O-ring sealed or vibration isolation vacuum hose.
ENCLOSURE:	NEMA type standard 19".
PURIFIER:	100% of atmosphere passes through moisture/oxygen purifier beds at room temperature. Oxygen removal capacity: 2.3cc O <sub>2</sub> /gm of reactant (4540 gm of reactant in M0-40 bed). Moisture removal capacity: 0.031 gm H <sub>2</sub> O/gm of molecular sieve (7260 gm of sieve in M0-40 bed).
REGENERATION:	Retort is isolated from the circulation system; reactant and absorbent are heated with a stainless steel sheathed heater inside the purifier column. Integral vacuum pump removes all residual gas.
INSTRUMENTATION:	Graphic flow diagram includes switches, flow indicator, vacuum gage and function lights...dial gage to monitor vacuum pump performance... adjustable automatic pressure regulation system and foot switch for controlling system pressure.
TESTS & CERTIFICATION:	No detectable leaks under vacuum with a calibrated helium mass spectrometer sensitive to $3 \times 10^{-10}$ std. cc/sec.

Table 1-2. M040-2 Purifier Dimensions

	M0-40-2V	M0-40-2H
PURIFIERS	DOUBLE	DOUBLE
HEIGHT (each)	68-1/2"	35"
WIDTH (each)	23"	37-1/4"
DEPTH (each)	25-1/2"	26"

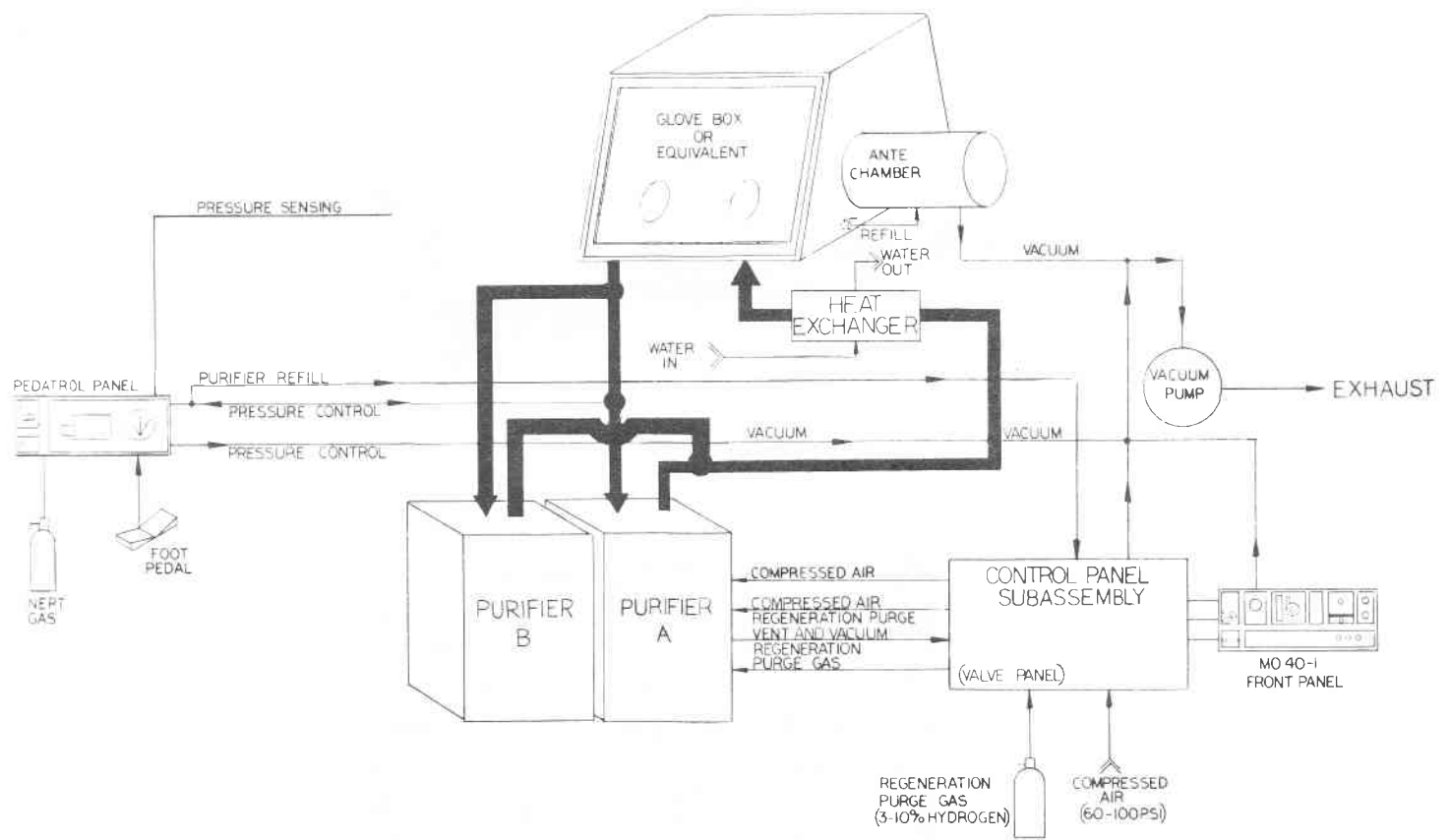

Figure 1-1. DRI-TRAIN/DRY-LAB Simplified System

M040-2-11/78

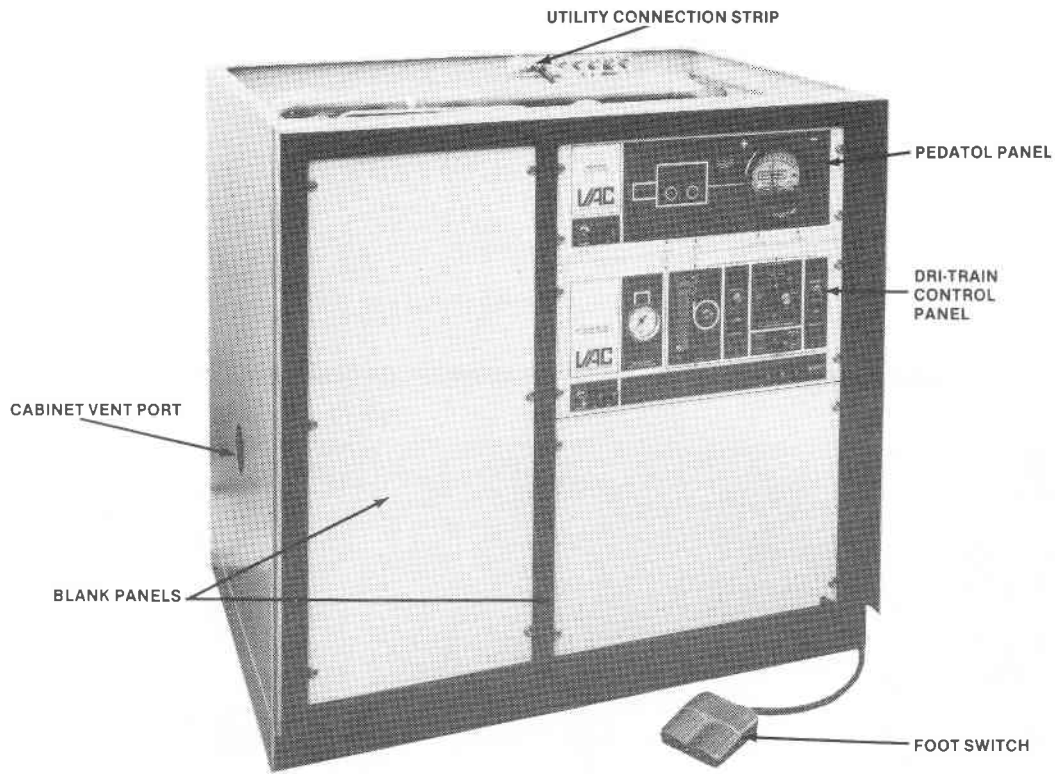

Figure 1-2. M040-2H Front View

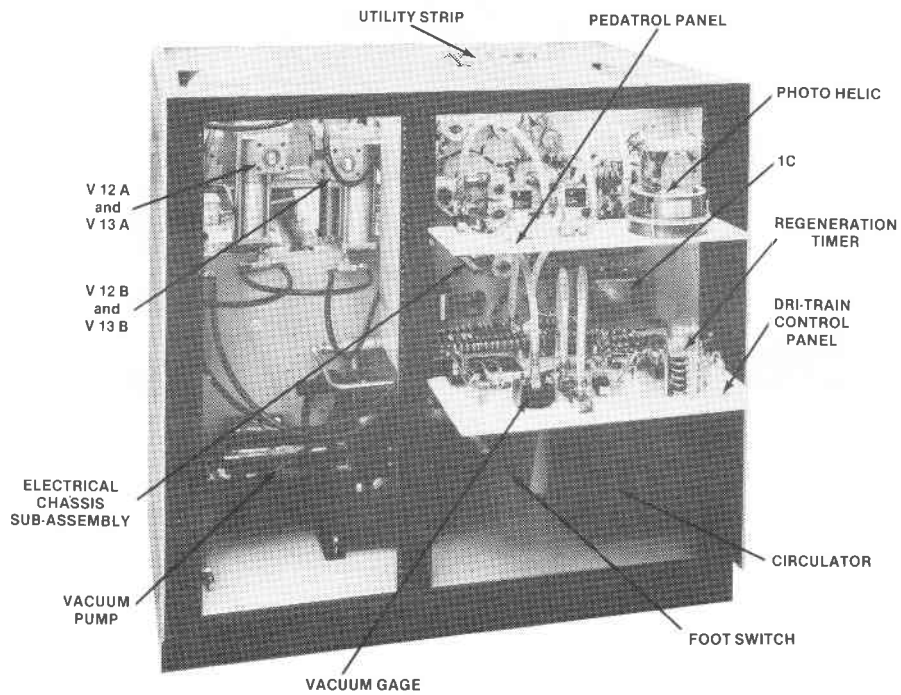

Figure 1-3. M040-2H Front View - Panels Open

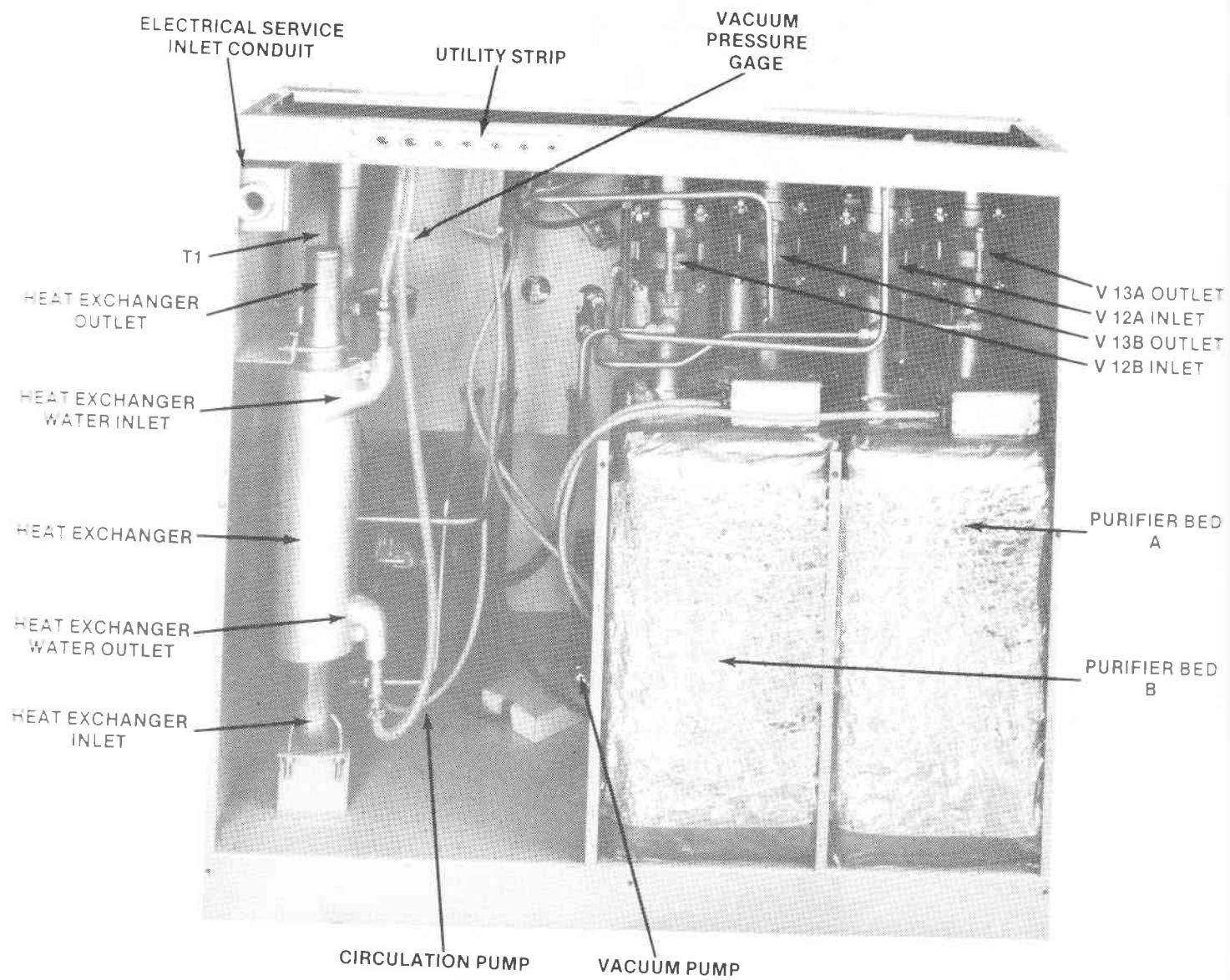

Figure 1-4. M040-2H Rear View

M040-2-11/78-R1-6/81



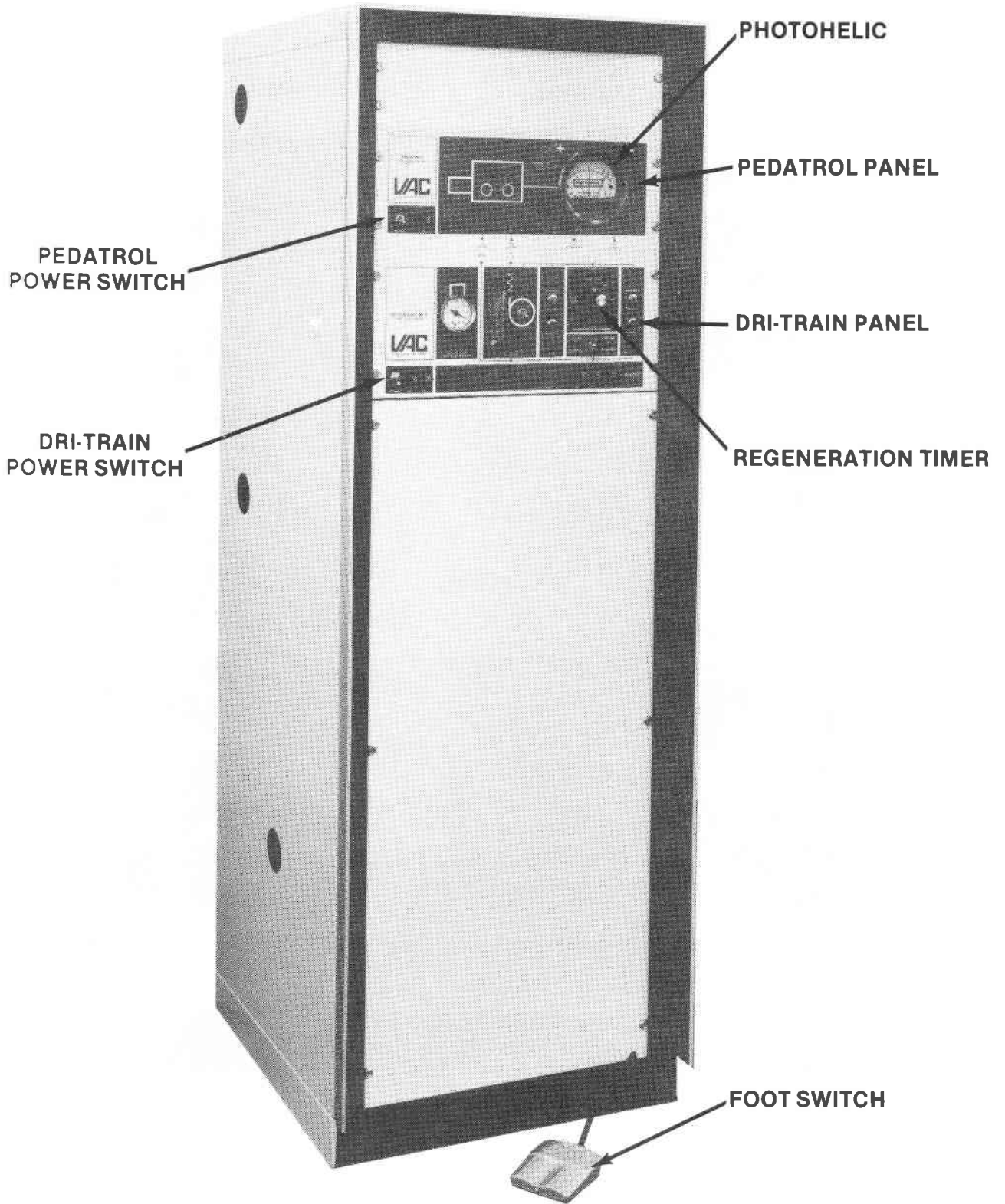

Figure 1-5. M040-2V Front View

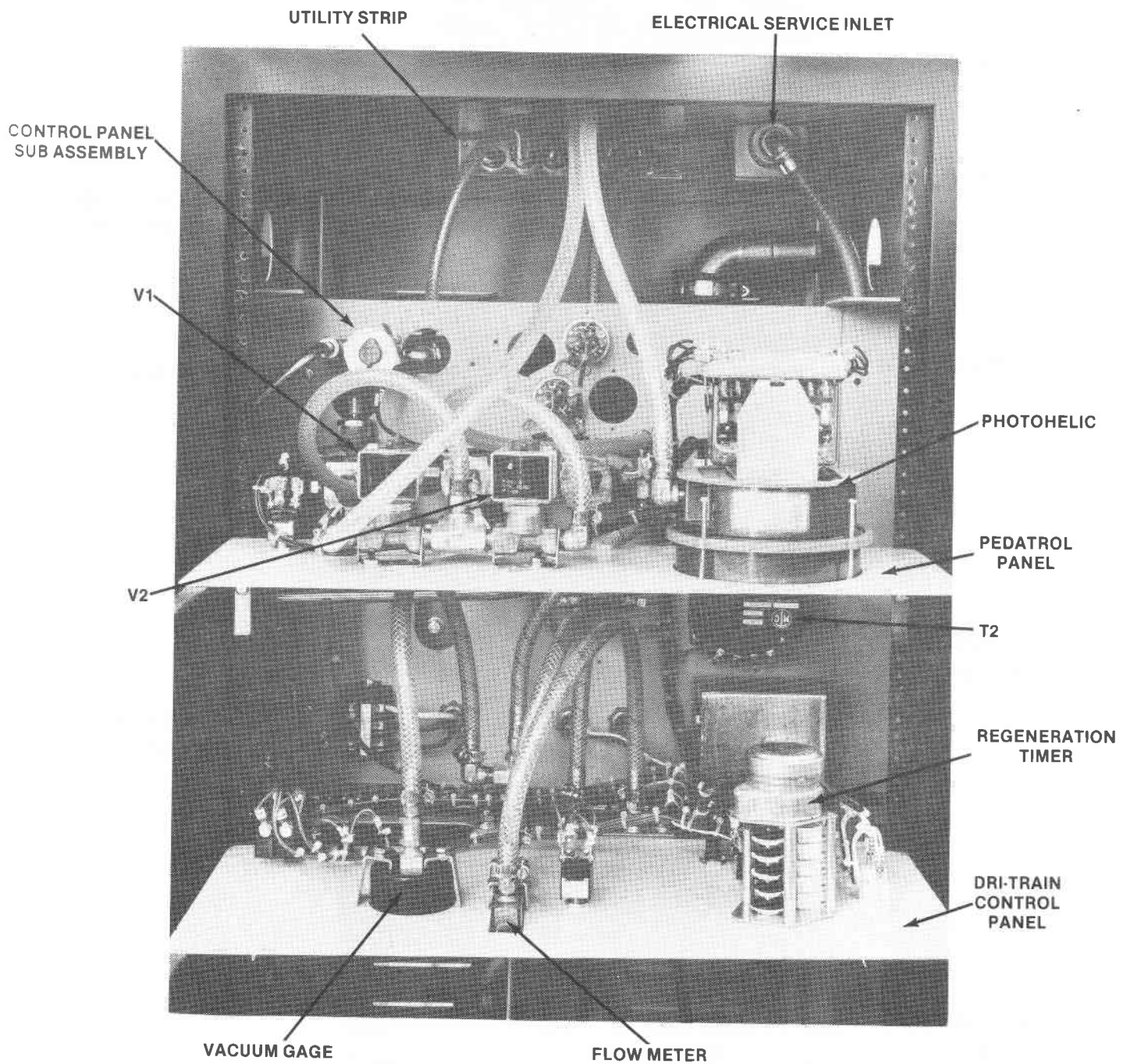

Figure 1-6. M040-1V Front View - Panels Open

M040-2-11/78-R1-6/81

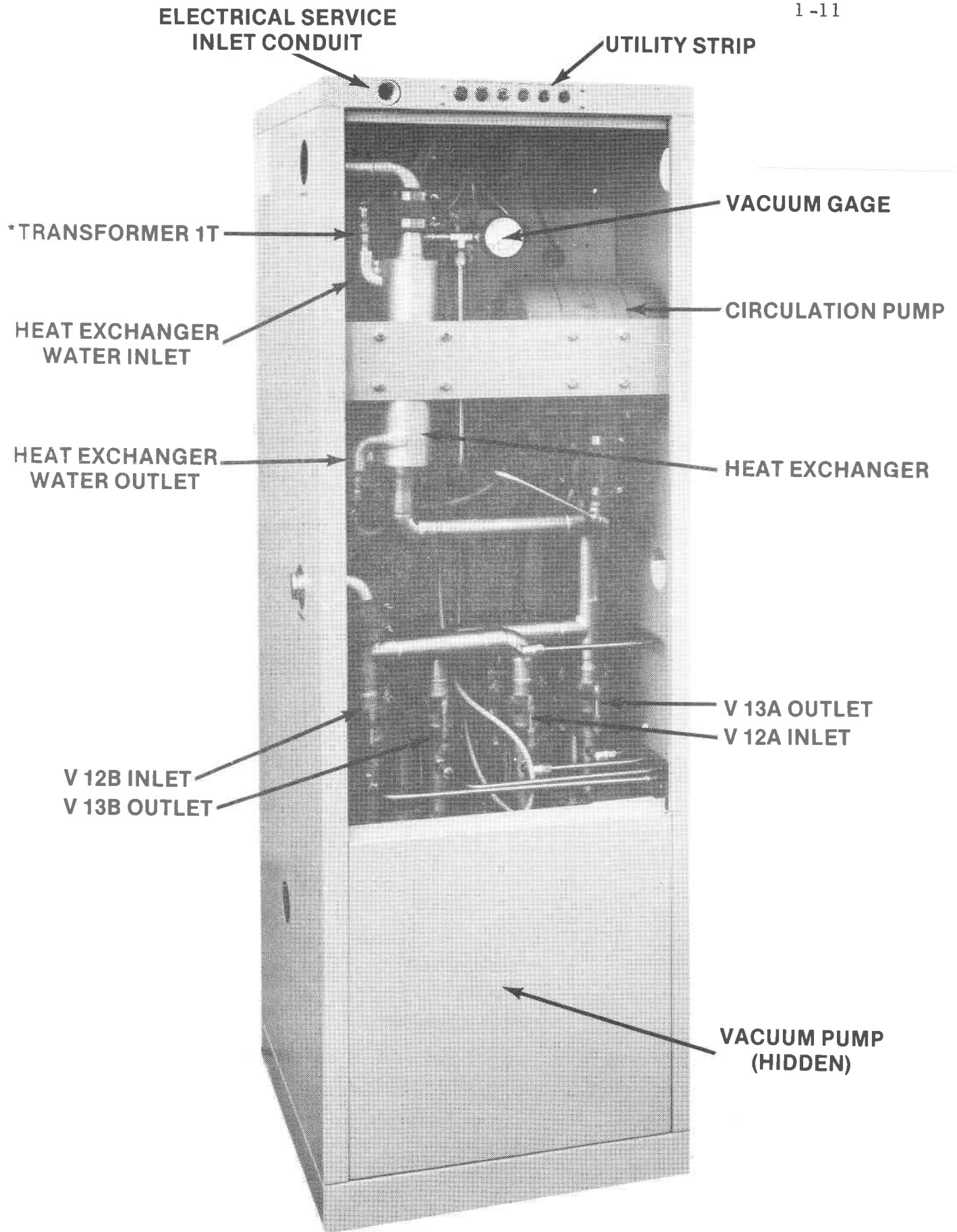

Figure 1-7. MO40-2V Rear View

\*TRANSFORMER 1T IS SECURED TO THE INNER LEFT HAND WALL.

2-0 INSTALLATION2-1 GENERAL

Installation of an M040 system requires that various electrical, water and gas utilities be provided. See Table 2-1 for detailed utility requirements.

2-2 ENVIRONMENTAL/SPACE REQUIREMENTS (Table 1-1)

The space required will depend on whether a horizontal or vertically packaged DRI-TRAIN is being installed. In all cases ample access space needs to be provided around the cabinet to facilitate normal servicing operations.

**Note**

Refer also to installation data provided for the glove-box or other equipment to be connected to the M040, to ensure complete system installations.

**WARNING**

DO NOT TURN ON ELECTRIC POWER UNTIL  
READY FOR INITIAL SETUP AS DETAILED IN  
SECTION-3 OF THIS MANUAL.

Table 2-1. Utility Requirements

UTILITY	SIZE OF CONNECTION	FLOW	PRESSURE	FUNCTION
Inert (Make-up) Gas	1/4" NPT	As Req.	20 psi (Approx.)	Used to replace gas lost in normal operation due to attrition.
Regeneration/ Forming Gas	1/4" NPT	1 CFM	As Req.	Used for purging the purifier.  Gas is usually argon, helium, or nitrogen, and has 3-10% hydrogen.
Compressed Air	1/4" NPT	N/A	60-125 psi	Used to operate purifier valves V12A, V12B, V13A, V13B.
Cooling Water	3/8" NPT inlet & outlet	1 GPM	As Req.	Used for cooling the gas passing thru the heat-exchanger. Temperature of this water should be 20°F lower than the desired temperature in the glovebox. A flow meter should be provided in the water line at the time of installation to allow monitoring the flow rate to ensure early detection of any line blockage.

Table 2-1. Utility Requirements (continued)

UTILITY	SIZE OF CONNECTION	FLOW	PRESSURE	FUNCTION
Purge Vent	1/4" NPT	As Reg.	N/A	Vent for regeneration/ forming gas during regeneration. Usually vented to outside exhaust system.
Pressure Sensing	1/4" NPT	N/A	N/A	Pressure sensing line connecting PC-1, pressure control unit to glove box.
UTILITY	CONNECTION	VOLTS/AMPS	PHASE	FUNCTION
Electrical	Junction Box	*208 VAC/ 15 Amps, or *220-240 VAC 15 Amps	Single 50/60 Hz	To supply electrical power for Pedatrol and Purifier operations.
*See paragraphs 2.4, 2.5 and 2.6				

NOTE: Vacuum Atmospheres recommends the use of copper or stainless tubing and fittings for all external plumbing connections. If in doubt, please consult with the VAC representative for your area or contact the factory directly.

2-3 ELECTRICAL REQUIREMENTS

The M040-2 (H or V models) require 208vac at 15 amps, single-phase, or 220-240vac at 15 amps, single phase. Connection to the M040 is made in a junction box using standard wire nuts. Provisions are made for the connection of electrical conduit to the M040 cabinet. (See Figure 2-1).

2-4 TRANSFORMER WIRING OPTIONS

The M040 units are shipped from the factory with the input transformer taps (Transformer 1T) configured to accept 208vac with 200-215vac as the voltage range.

(See note 5 on the schematic of Figure 5-2.)

With this transformer configuration, when the input voltage is 208vac, the output from the transformer to the system components is 230vac. This is the voltage required by the operating units of the M040.

2-5 230 VOLT OPERATION

If the M040 user has a 230vac power (220-240vac) source, the transformer (.IT) may be wired per note 6 on Figure 5-2. This effectively removes the transformer from the system.

2-6 TRANSFORMER CONNECTIONS

If the transformer is to be rewired for 230vac service, access to the connection points may be obtained by removing the cover plate on the transformer. This transformer is the large grey unit

mounted inside the M040 cabinet near the electric power conduit box.

## 2-7 UTILITY CONNECTIONS

Provision has been made with plumbing receptacles (on rear of equipment frame) for the connection of all gas, air and water utilities to/from the outside of the cabinet. (See Figure 2-1). The connections for utilities are the same on the vertical and horizontal models of the M040-2.

Table 2-1 (Utility Requirements) lists all the gas, air, water, vent, and electrical requirements for the M040. It also presents other pertinent details involving special conditions, flow-rates, pressures, etc.

## 2-8 GAS REQUIREMENTS

Two separate types are required for M040 operation:

- One gas of the chemical composition desired in the normal circulation atmosphere of the glove-box. It is referred to as "Inert Gas" or "Make-Up Gas."
- The other has the same basic properties as that of the system, but which contains 3-10 percent hydrogen. This gas is for use in the regeneration operation which requires a Hydrogen-rich type, referred to as Regeneration or Regeneration/Forming Gas.

These two utilities are connected to the M040 through clearly



marked pipe receptacles on the utility connection strip (Figure 2-1).

It is recommended that a flow meter and a throttle valve be installed in the regeneration/forming gas supply line to facilitate setting-up the required gas flow of 1 CFM. The flow meter must be selected for the type of gas that is the major component of the mixture; (argon, helium or nitrogen).

#### 2-9 COMPRESSED-AIR

A supply of compressed-air with a pressure in the range of 60-125 psi must be provided to the utility strip inlet. This compressed air is used as a source of power to activate the four air-operated valves on the two purifiers (Purifier A-V12A and V13A, Purifier B-V12B and V13B).

#### 2-10 VENTING

The regeneration/forming gas vents from the system to an outlet on the utility strip. This outlet should be plumbed to a safe, free-air point.

The vacuum pump exhaust may contain either system inert gas or regeneration/forming gas.

The vacuum pump exhausts through a port on the pump and may be plumbed to any location at the customer's discretion.

#### 2-11 WATER REQUIREMENTS

Water must be provided for cooling purposes to the heat exchanger.

It must have a minimum flow rate of 1 GPM, and water temperature should be 20°F lower than the temperature desired for the gas circulating in the system. Connections are made at the utility strip for the water supply and the water outlet or drain lines.

#### 2-12 ATMOSPHERIC MONITORING

Leak and atmospheric testing are explained in Section-7 (Maintenance) of this manual. Leak testing of the M040 system is normally performed under "power-on" conditions.

Instrumentation is available for monitoring the chemical content of numerous types of atmospheres. For additional data on monitoring methods and available instruments, contact Vacuum Atmospheres Company directly.

#### 2-13 INERT GAS PLUMBING

The inert gas is used to pressurize the glove-box, and is controlled by the Pedatrol. Pressure regulation is 20 psi for normal operation, and 40 psi for purging.

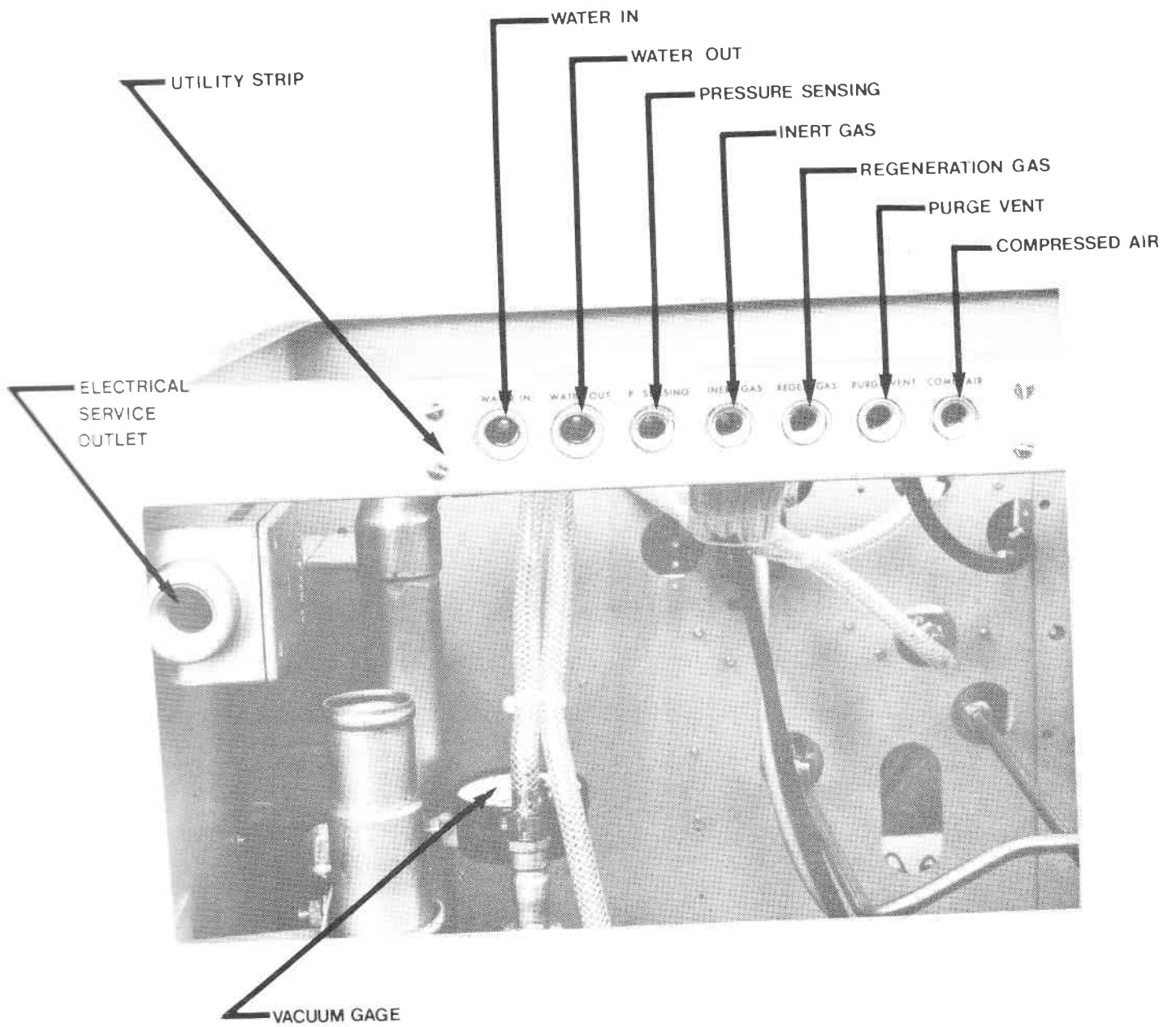

Figure 2-1. Utility Connection Strip

3-0 INITIAL SETUP

It is strongly recommended that anyone attempting to setup and operate the DRI-TRAIN read Section 5 (Theory of Operations) and Section 7 (paragraphs 7-9 through 7-12 - Leak Testing) in this manual. Complete all operations of Section 2 prior to performing any of the operations in this section.

Initial setup of the M040-2 will follow the general sequence which follows:

- Electrical checkout
- Establishing an inert atmosphere
- Pressure control system checkout
- Initial regeneration

**Note**

If difficulty is encountered in performing any of the steps of this section, refer to the appropriate portion of Sections 5, 6 or 7 in the manual.

3-1 ELECTRICAL CHECKOUT3-2 INITIAL CONDITIONS

From this point on, the DRI-TRAIN is assumed to be fully assembled, all utilities connected, and connection made to a glove-box (such as the DRI-LAB or the VAC/LAB units manufactured by Vacuum Atmospheres Company).

Initial switch positions (See Figures 3-1 and 3-2) prior to electrical checkout are:

- DRI-TRAIN control panel power switch OFF.
- PEDATROL panel power switch OFF.
- CIRCULATOR switch OFF.
- PURIFIER switch in CIRCULATE B REGENERATE A position or CIRCULATE A REGENERATE B position.

**Note**

If the purifier switch is in CIRCULATE A (REGENERATE B) position, Purifier A will be in Circulation mode and B in Regeneration mode.

These modes can be reversed by flipping the switch to CIRCULATE B REGENERATE A position.

**CAUTION**

NEVER FORCE THE REGENERATION-PROGRAMMER SWITCH IN THE COUNTER-CLOCKWISE DIRECTION AS THIS ACTION MAY DAMAGE THE SWITCH.

3-3

PROCEDURE FOR ELECTRICAL CHECKOUT

**CAUTION**

THERE IS NO SEPARATE SWITCH FOR THE VACUUM PUMP; THEREFORE, THE PUMP WILL START WHEN THE DRI-TRAIN POWER SWITCH (ON THE MAIN CONTROL PANEL) IS TURNED ON. AS POWER COMES ON AND THE VACUUM PUMP STARTS, THE PURIFIER VALVES (V12A AND V13A OR V12B AND V13B) MAY ACTUATE CAUSING A SIGNIFICANT ACTUATION NOISE.

M040-2-11/78

Follow the steps of Table 3-1 and obtain the stated effects in each step, prior to proceeding to the next. After all the steps in Table 3-1 have been performed, go to paragraph 3-4.

Table 3-1. Electrical Checkout Procedure

STEP	ACTION	EXPECTED RESULT
1.	POWER switch to ON.	a. Vacuum pump should start. b. Vacuum manifold gage should pump down to 26" Hg. to 30" Hg. c. CIRCULATE A or B light should be ON.  Step 1 c. depends on PURIFIER switch position.
2.	PURIFIER switch to CIRCULATE B (REGENERATE A).	a. CIRCULATE B light ON. b. Purifier A valves (V12A and V13A) close. - Note audible sound. c. Purifier B valves (V12B and V13B) open. - Note audible sound.
THEN		
3a.	PURIFIER switch to CIRCULATE A (REGENERATE B).	a. CIRCULATE A light ON, and CIRCULATE B light OFF. b. Purifier A valves (12A and 13A) open.

Table 3-1 (continued)

STEP	ACTION	EXPECTED RESULT
		<ul style="list-style-type: none"> <li>- Note audible sound.</li> <li>c. Purifier B valves (V12B and V13B) close.</li> <li>- Note audible sound.</li> </ul>
3b.	Return the PURIFIER switch to CIRCULATE B (REGENERATE A) position and perform the following:	<ul style="list-style-type: none"> <li>a. CIRCULATE B light on, and CIRCULATE A light off.</li> <li>b. Purifier B valves (V12B and V13B) open.</li> <li>- Note audible sound.</li> <li>c. V7 energized.</li> </ul>
4.	Glove-box inlet and outlet valves open.	<ul style="list-style-type: none"> <li>a. Open manually.</li> </ul>
5.	Circulator Switch to ON.	<ul style="list-style-type: none"> <li>a. Circulator flowmeter should indicate gas flow through the glove-box.</li> <li>b. There should also be a good flow at the glove-box inlet and outlet valves.</li> </ul>
6.	Set flowmeter to 4.	This is for indication only. A future drop in reading will serve as an indication of plugged filters or other problems resulting in reduced flow.



Table 3-1 (continued 2)

STEP	ACTION	EXPECTED RESULT
7.	Rotate regeneration timer to HEAT.	<ul style="list-style-type: none"> <li>a. REGENERATE A light ON.</li> <li>b. Purifier heat is automatically applied. Surface of the purifier should feel warm within 60 minutes.</li> </ul>
8.	Rotate regeneration timer to PURGE.	<ul style="list-style-type: none"> <li>a. Purifier heat should continue.</li> <li>b. Regeneration light should remain ON.</li> <li>c. Solenoid valves V4 and V5A should energize.</li> </ul>

**Note**

Solenoid valve actuation should be checked with a magnet. Hold the magnet about 1/2" from the red cap on the solenoid. When the valve is energized, the magnet will vibrate noticeably.

9.	Rotate regeneration timer to "EVACUATE."	<ul style="list-style-type: none"> <li>a. REGENERATE A light remains ON.</li> <li>b. Solenoid valve V3 energized, and V4 and V5A deenergized. Check</li> </ul>
----	--	--

Table 3-1 (continued 3)

STEP	ACTION	EXPECTED RESULT
		<p>with a magnet.</p> <p>c. Vacuum pump manifold gage should drop to near zero pressure and then slowly return to 26"-30" of Hg. vacuum.</p> <p>d. Purifier heat is no longer applied.</p>
10.	Rotate regeneration timer to "REFILL."	<p>a. REGENERATE A light remains ON.</p> <p>b. Solenoid valve V6 should energize and V3 should deenergize.</p> <p>c. Gloves should withdraw into the glove-box.</p>
11.	Rotate regeneration timer to STOP.	<p>a. Regeneration A light should go out.</p> <p>b. Valves V4, V5A, V6 should all be deenergized. V7 should still be energized.</p>

Table 3-1 (continued 4)

STEP	ACTION	EXPECTED RESULT
<p><b>Note</b></p>	<p>Under normal operating conditions, Purifier A should be fully regenerated and on standby; ready to take over when Purifier B must be regenerated.</p> <p>The differences in Regeneration operation for Purifier B are as follows:</p> <ul style="list-style-type: none"> <li>- Step 7 item c. Valve V7 deenergized</li> <li>- Step 8 item c. Valve V5B should energize</li> <li>- Step 9 item b. Valve V5B should deenergize</li> <li>- Step 11 item b. Valve V5B should be deenergized</li> <li>- Step 7 item a. REGENERATE B light comes ON</li> <li>- Step 9 item a. REGENERATE B light remains ON</li> <li>- Step 10 item a. REGENERATE B light remains ON</li> <li>- Step 11 item a. REGENERATE B light Goes out</li> <li>- Step 11 item b. V7 should be deenergized</li> </ul>	
12.	<p>Pedatrol power switch to OFF.</p> <p>Depress the R-foot switch momentarily.</p>	<p>a. Valve V2 should energize to let gas into the glove-box. Audible click can be heard.</p>

Table 3-1 (continued 5)

STEP	ACTION	EXPECTED RESULT
		<ul style="list-style-type: none"> <li>b. Gloves should push out from the box.</li> </ul>
13.	Depress the L-foot switch momentarily.	<ul style="list-style-type: none"> <li>a. Valve V1 should energize momentarily. Audible click can be heard.</li> <li>b. Gloves should be drawn into the glove-box.</li> <li>c. Vacuum manifold gage pressure should drop momentarily.</li> </ul>
14.	Pedatrol POWER switch to ON. Rotate (-) red needle counter-clockwise past black indicator needle.	<ul style="list-style-type: none"> <li>a. Valve V2 should energize.</li> <li>b. Pressure should rise.</li> </ul>
15.	Rotate (+) red needle clockwise past black indicator needle.	<ul style="list-style-type: none"> <li>a. Valve V1 should energize.</li> <li>b. Pressure should decrease. See item 13.</li> </ul>
16.	Set red pointers for a plus and minus one.	

3-4

ESTABLISHING AN INERT ATMOSPHERE**Note**

The steps of paragraph 3-3 must be completed prior to attempting to establish an inert atmosphere in the glove-box.

**CAUTION**

- BE CERTAIN THAT THE GLOVE-BOX CIRCULATION VALVES ARE OPEN AT THIS TIME. ANY TIME THE DRI-LAB OR VAC-LAB ISOLATION VALVES (DLV-1 AND DLV-2) ARE CLOSED, THE PHOTOHELIC AND CIRCULATOR SWITCHES MUST BE OFF.

3-5

PURGING THE SYSTEM

With glove-box inlet and outlet valves open, set the PHOTOHELIC red pointers (Figure 3-3) as follows:

- Left-hand pointer to approximately 5" on the positive-pressure side (left-hand side).
- Right-hand pointer to approximately 4" on the positive pressure side (left-hand side).

Then,

- Remove one of the "service-port" plugs on the DRI-LAB or VAC-LAB. This will provide an exit for the inert gas used to purge the glove-box.

- Raise the pressure regulator setting on the make-up gas supply (Inert gas) from the normal 20 psi to 40 or 50 psi to speed up the purging process.
- The make-up gas supply flow and the port opening should be balanced so that the DRI-LAB pressure does not drop below one to two inches of positive pressure on the PHOTOHELIC scale.
- Replace the service port plug after the purge is completed.

**Note**

As the gas cylinder nears empty, plug the service port so that the gloves will not drop completely. For a good purge, approximately eight DRI-LAB volumes of gas should be used. Perform part of the purge with the DRI-LAB inlet valve (DLV-1) closed and part with the outlet valve (DLV-2) closed, thus forcing gas through the inlet and outlet valves.

3-6

NON-DRI-LAB SYSTEMS

For VAC-LABS, evacuate and refill the VAC-LAB and the DRI-TRAIN with one of the purifiers in the CIRCULATE mode, but with the CIRCULATOR switch in the OFF position.

3-7

PRESSURE CONTROL TESTS

Pressure in the DRI-LAB (or other types of glove-boxes) is

automatically controlled and indicated by the PHOTOHELIC on the Pedatrol panel.

Pressure is controlled and read to 1/10" of water column height (pressure equivalent). The left and right red pointers are used to set the upper and lower pressure limits.

Two small knobs are used to set the position of the red pointers. These pointers are normally set about 1" of water from each other: usually about 1/2" above and below zero (Ambient). Refer to Section-5 (Theory of Operation) of this manual for additional information on operation of the PHOTOHELIC and the foot switch.

Depressing the R-side of the foot switch raises the DRI-LAB pressure and depressing the L-side lowers the DRI-LAB pressure. This function is intended primarily for positioning the gloves in or out of the glove-box.

3-8

#### PROCEDURE-PRESSURE TESTING

- a. Set the PHOTOHELIC pointers as follows:
  - Set right-hand red pointer to 1" above the zero mark.
  - Set the left-hand red pointer to 1" below the zero mark.
- b. Observe the effect of the foot switch on the position of the rubber gloves.

- Depress the "R" side of the foot switch. The gloves should push out from the box.
  - Depress the "L" side of the foot switch. The gloves should begin to withdraw to or into the box.
- c. Test the pressure limiting action of the PHOTOHELIC.
- Depress the "L" side of the foot switch and hold it.  
The pressure, as read on the PHOTOHELIC gage, should decrease until it reaches the pressure set on the right-hand pointer.  
Valve V2 will begin to cycle and admit gas into the system, to make up for the gas being removed by the vacuum pump through valve V1.  
The pressure will hold at about the preset point.
  - Depress the R-side of the foot switch and hold it.  
Pressure will increase as long as the switch is activated - and limited only by the pressure available from the gas supply, the flow rate setting, and the amount of gas the vacuum pump can bleed off through V1.

**Note**

The PHOTOHELIC will cycle valves V1 and V2 as necessary to



maintain the pressure in the system within the preset limits established by setting the two limit pointers.

3-9 INITIAL REGENERATION

For initial regeneration it is recommended that the normal regeneration procedure be repeated two or three times since the oxygen reactant in a purifier is shipped in a completely saturated condition. See Section-5 for more details on the purifier and the regeneration procedure.

3-10 REGENERATION SEQUENCE-SIMPLIFIED

To perform the required regeneration for the first time on a new or saturated purifier, use the following procedure:

- a. Establish an inert atmosphere in the glove-box.
- b. DRI-TRAIN control panel power switch to "ON."
- c. PURIFIER switch to REGENERATE A or REGENERATE B.
- d. REGENERATION TIMER toward START until the applicable Regeneration light comes on.
- e. Pedatrol panel POWER switch to ON.

Regeneration will now proceed under the automatic control of the Timer. The entire process will require 12 hours.

The regenerated purifier will then be on standby (See Table 3-1).

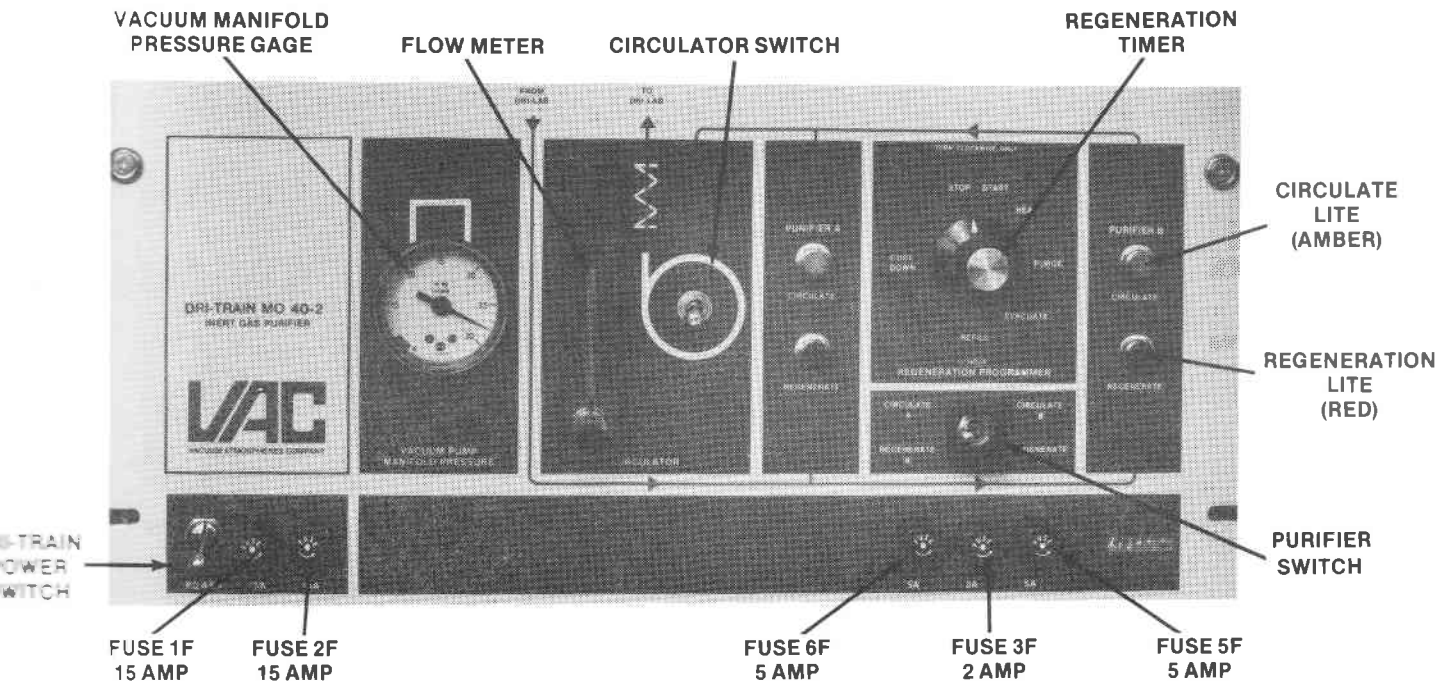

Figure 3-1. DRI-TRAIN Control Panel - Front View

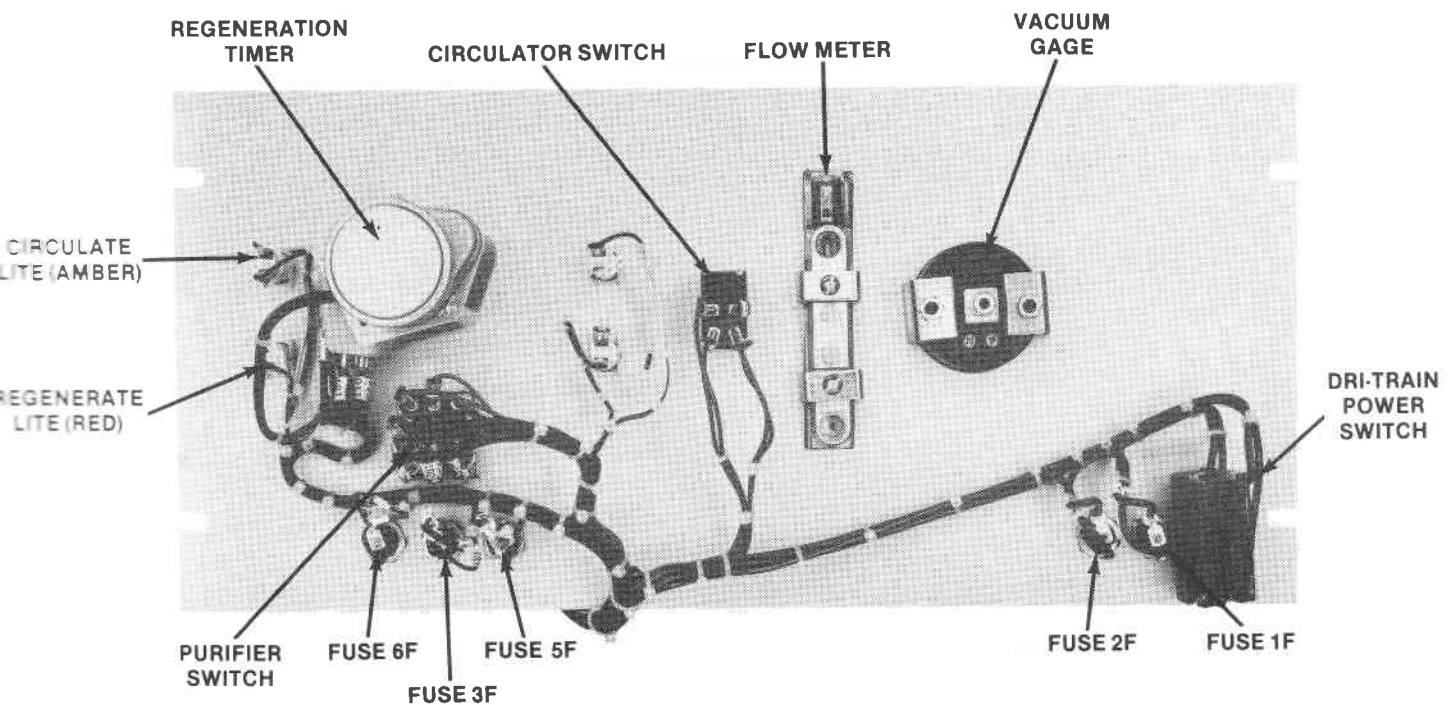

Figure 3-2. DRI-TRAIN Control Panel - Rear View

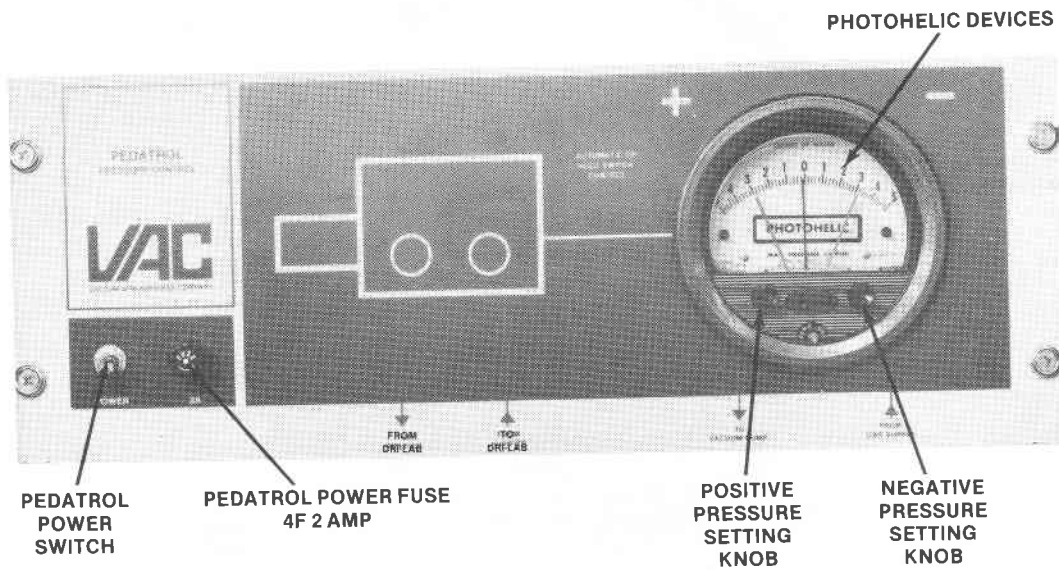

Figure 3-3. Pedatrol Panel - Front View

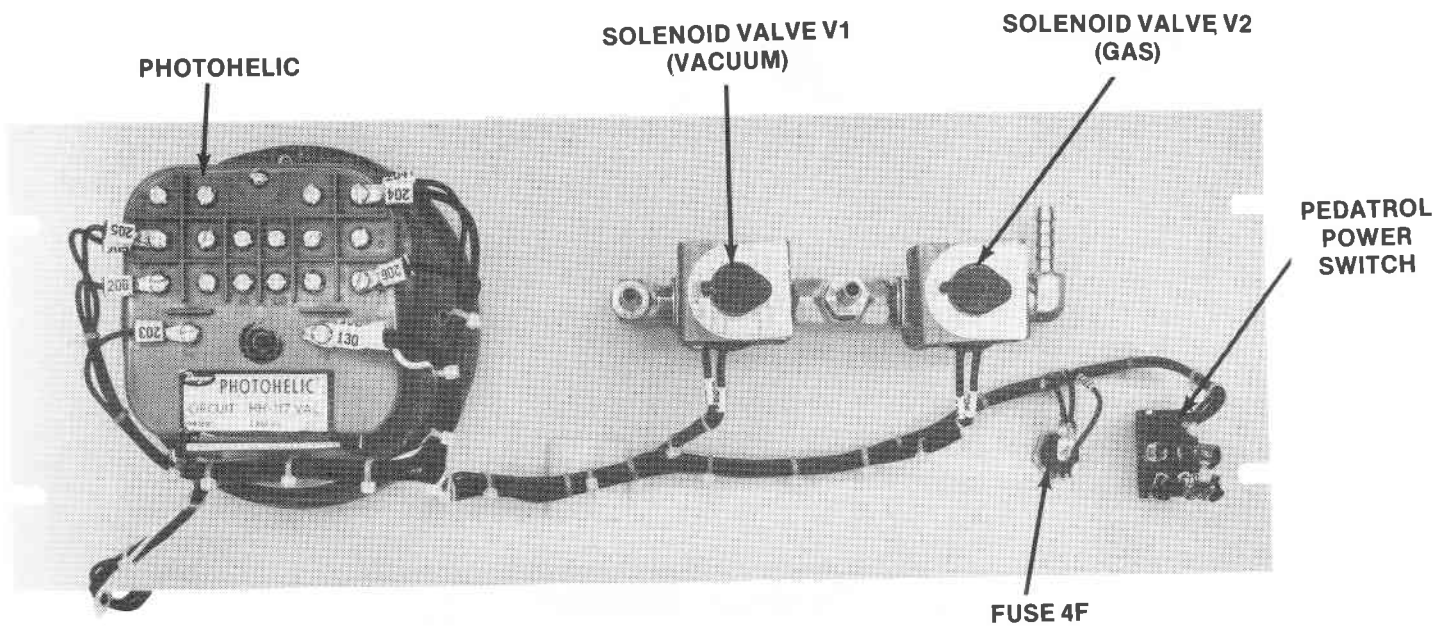

Figure 3-4. Pedatrol Panel - Rear View

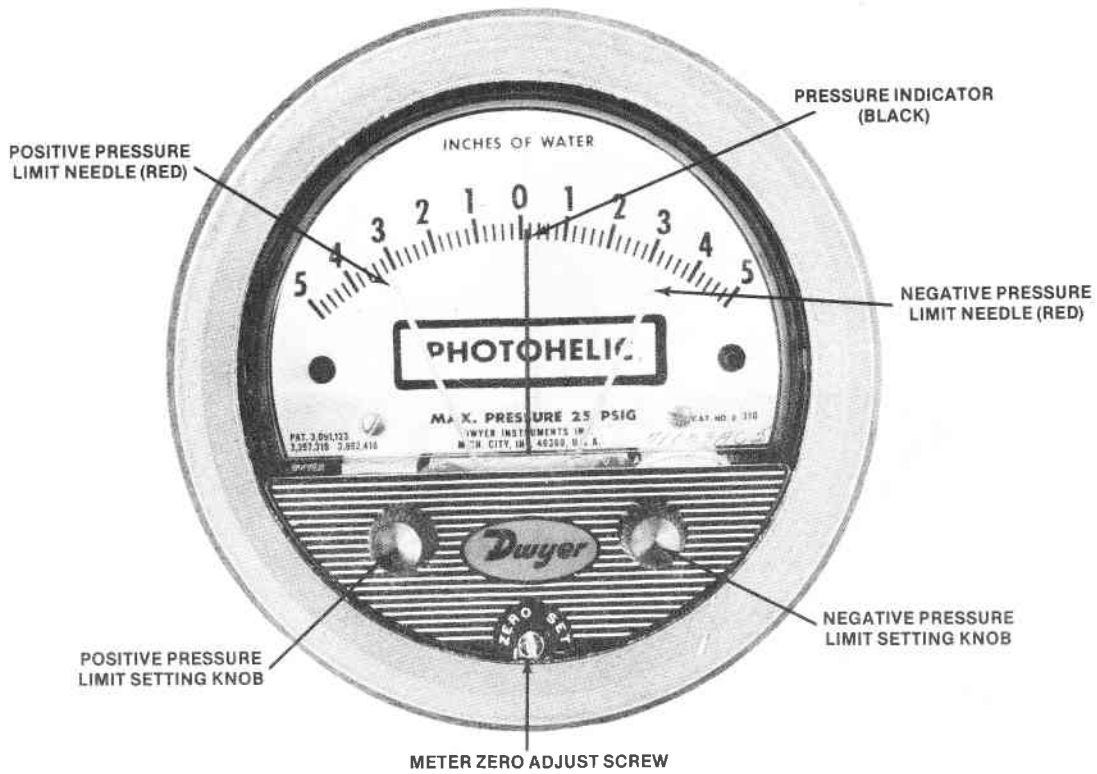

Figure 3-5. Photohelic - Front View

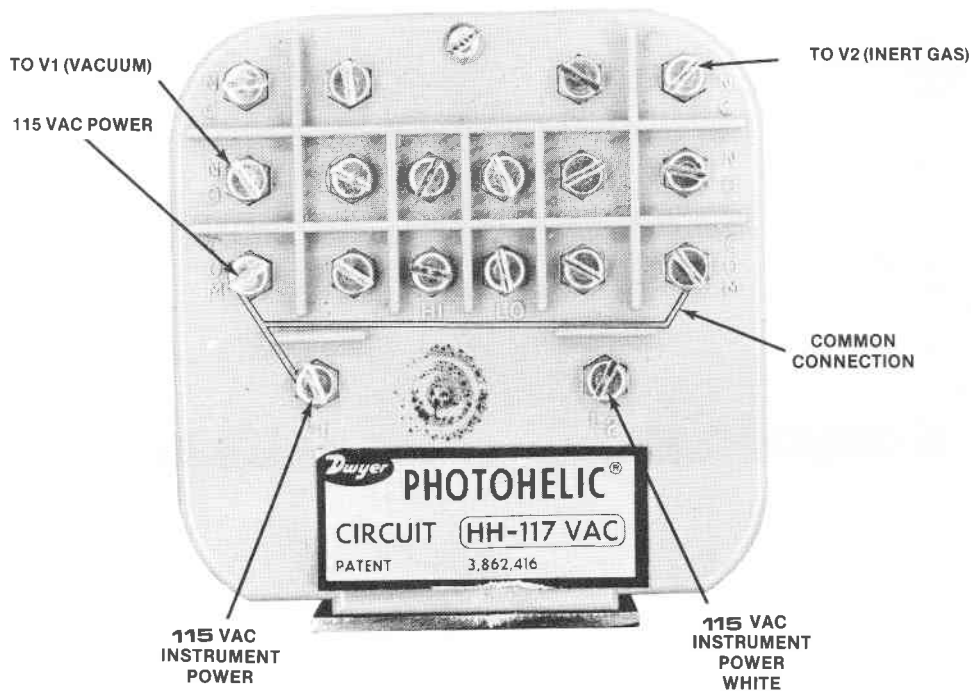

Figure 3-6. Photohelic - Rear View

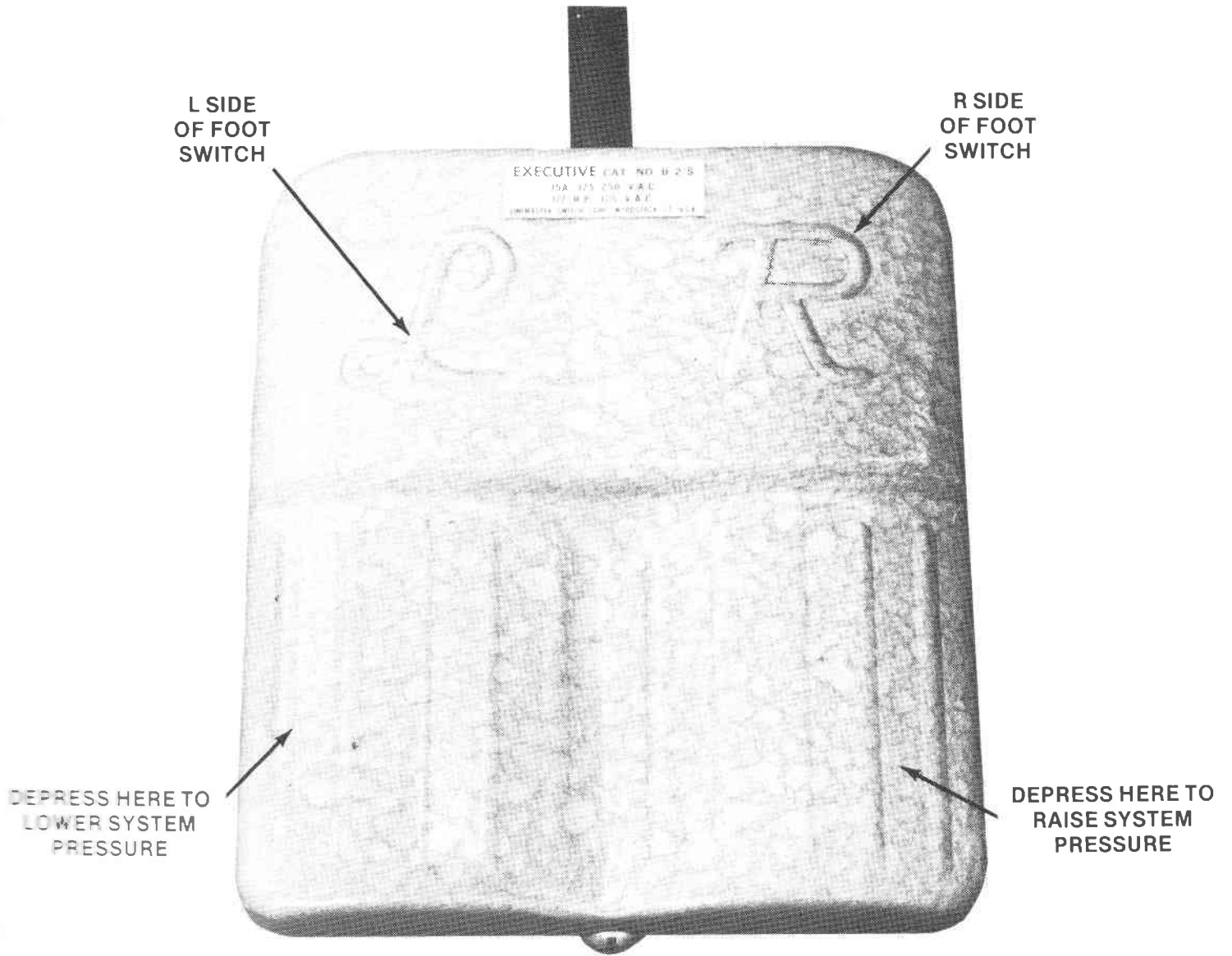

Figure 3-7. Foot Switch - Pedatrol

4-0 OPERATING INSTRUCTIONS4-1 GENERAL

Operations involving the DRI-TRAIN system are divided into three basic categories in this manual. These categories are:

- Daily operations
- Regeneration
- Periodic and special operations

A table of all switches, controls and indicators is presented for the operator's convenience; (Table 4-1).

The use of certain contaminants in the glove-box or introduction of contaminants to the system will destroy the purifying action and damage the purifier's chemicals.

NOTE THE FOLLOWING WARNINGS:

**WARNING**

SULPHUR AND SULPHUR COMPOUNDS SUCH AS  $H_2S$ ,  $RSH$ ,  $COS$ ,  $SO_2$ ,  $SO_3$ , ETC. WILL POISON THE REACTANT MATERIAL IN THE DRI-TRAIN AND, THEREFORE, SHOULD NOT BE USED IN AN ATTACHED GLOVE-BOX.

LARGE QUANTITIES OF HALIDES, CHLORIDES, HALOGENS (FREON), ALCOHOLS, HYDRAZINE, PHOSPHENE, ARSINE, ARSINATE, MERCURY

AND SATURATION WITH WATER MAY ALSO DEACTIVATE THE OXYGEN REACTANT. THE MOISTURE ADSORBENT IS NOT AFFECTED BY THESE CHEMICALS. IF ANY OF THESE POISONS ARE TO BE USED IN THE GLOVE-BOX SERVED BY A DRY-TRAIN, A SUITABLE TRAP SHOULD BE INSTALLED IN THE LAB OR IN THE CIRCULATING LINE AHEAD OF THE DRI-TRAIN.

#### 4-2 OPERATING MODE

The DRI-TRAIN system is designed and intended for continuous operation. It need never be turned off except for maintenance purposes.

#### 4-3 SYSTEM TURN-ON

Connect all gas, water and electrical utilities as outlined in Sections-2 and -3.

Turn ON the power switches on the DRI-TRAIN and PEDATROL panels. The vacuum pump motor should be running as soon as the power is applied to the system.

#### **Note**

The purifier switch should be in CIRCULATE A or CIRCULATE B position.



4-4 WAIT-TIME AFTER TURN ON

The time required for the DRI-TRAIN to remove oxygen and moisture to any desired level from a glove-box is dependent on the size of the glove-box, the initial oxygen and moisture levels, and the present chemical state of the operating purifier. The present state of this purifier depends primarily on the time elapsed since the last time the purifier was regenerated, and the amount of oxygen and moisture to which it has been exposed.

The graph of Figure 4-1 depicts the time, measured by Vacuum Atmospheres Company, required to recover measured amounts of oxygen from a glove-box. This data was taken under carefully controlled, laboratory conditions.

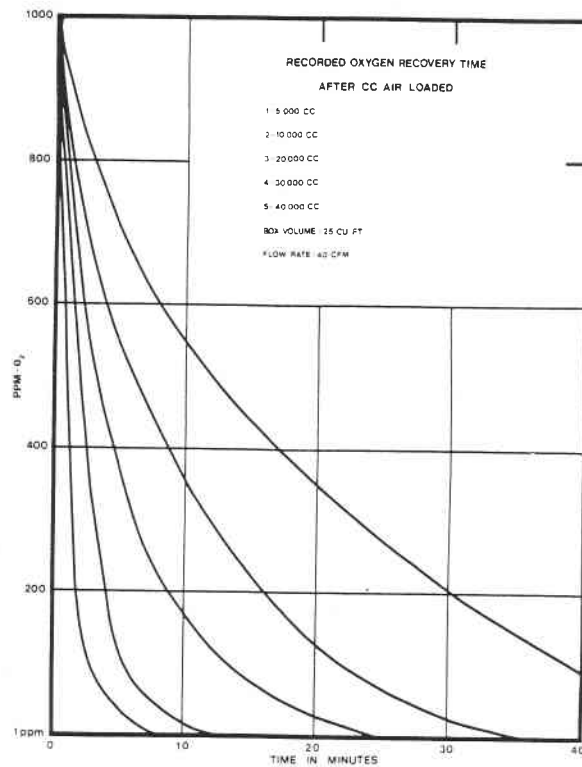

Figure 4-1. Oxygen Recovery Rates

4-5 CONTROLS AND INDICATORS

Table 4-1 presents the function of all controls and indicators. This list is arranged for quick reference by operators without a need to check the text (see pages 4-5 and 4-6).

4-6 DAILY OPERATIONS

Daily operation of the DRI-TRAIN is comprised of two basic types of activity. The first consists of monitoring the utilities on a periodic basis to make sure there is always an adequate supply of gas for each day's activities. Monitoring of gas supplies and checking the flow rate and temperature of the heat exchanger water supply, should be done just prior to beginning operations each day.

The second type of daily activity involves controlling the pressure in the glove-box. This requires the close regulation of the atmospheric pressure in the system, and is done as required when the equipment is in operation.

The system pressure is controlled in two ways:

- a. The Photohelic unit maintains the pressure within preset limits established by setting the high and low pressure needles on the face of the Photohelic.
- b. Within the limits set by the Photohelic needles, the system pressure may be varied up or down by depressing the "R" (Raise pressure) or the "L" (Lower pressure) side of

Table 4-1. List of Controls and Indicators

<u>ELECTRICAL SWITCHES</u>	
DRI-TRAIN power	Supplies power to energize all lamps, valves, heaters, motors, etc. Turns the vacuum pump on directly.
PEDATROL power	Supplies power to the PHOTOHELIC. (The foot switch is not dependent upon the PEDATROL power switch.)
CIRCULATOR	Supplies power to the CIRCULATOR motor (Blower).
PURIFIERS	Select normal circulation or regeneration mode, with one purifier operating in one mode, and the second in the other.
<u>FUSES</u>	
DRI-TRAIN panel	
1F-15 amps	Fuses one line (L1) of A.C. input power
2F-15 amps	Fuses one line (L2) of A.C. input power
3F-2 amps	Fuses the regeneration circuits
4F-2 amps	Fuses the Photohelic circuits
5F-5 amps	Fuses the purifier heater
6F-5 amps	Fuses the purifier heater
<u>LIGHTS-INDICATORS</u>	
CIRCULATE - amber	Indicates the system is in one CIRCULATE mode, with the circulation system operating and the main circulate valves (V12A and V13A or V12B and V13B), open.
REGENERATE - red	Indicates the system is in one REGENERATION mode. The regeneration timer is operating, and the circulation valves (V12A and V13A or V12B and V13B) are closed.

Table 4-1 (continued)

FOOT SWITCH

"R" Side	Depressing the "R" side of the switch will cause inert gas to be injected into the glove-box by valve V2. This will raise the glove-box pressure and push the gloves outward.
"L" Side	Depressing the "L" side of the foot switch will cause gas to be removed from the glove-box by venting it to the vacuum system through valve V1. This will draw the gloves inward to the glove-box.

GAGES

Vacuum Manifold	Measures vacuum pressure at the vacuum pump inlet.
Flow meter	Measures gas flow rate in the main circulation lines. (Relative indication only.)
Pressure Gage (Compound)	Measures positive or negative pressure in the main gas circulation system. (0-30" Hg VAC, 0-30 psig).

PHOTOHELIC

Reads positive or negative pressure inside of the glove-box. It also provides settable needles for presetting the pressure limits of the glove-box atmosphere.

REGENERATION PROGRAMMER

Move knob clockwise until red regeneration light comes on. This starts regeneration for the purifier selected. The knob will continue to move clockwise during the 12 hour regeneration cycle, and shows where in the cycle the unit is. At completion of the cycle the knob will be back at its original position.

the foot switch.

Foot switch operation is independent of the Pedatrol power. When Pedatrol power is OFF, the foot switch can vary system pressure above or below the limits set on the Photohelic.

#### 4-7 MONITORING UTILITIES

Monitoring operations should be done at periodic intervals when the DRI-TRAIN system is in operation. There are several things which should be monitored during system operation. These are:

- The glove-box atmosphere for chemical purity. The type of monitoring equipment varies from one system to another.
- Gas flow rate in the total system. It is indicated by the flowmeter on the control panel.

The vacuum manifold pressure is indicated by the gage on the control panel. System vacuum should be 26" to 30" of mercury (Hg), nominal. A compound vacuum/pressure gage is mounted on the circulation plumbing lines inside the cabinet. This compound gage is used when evacuating or pressurizing the DRI-TRAIN during leak testing. See Figure 1-4.

- The remaining quantities of inert and regeneration gas must be monitored often enough to insure an adequate supply for each day's operations.
- The presence of an adequate supply of cool water to the

heat exchanger should be checked at regular intervals, especially, each time the system is restored to operation after having been out of service for any period. Failure of the water supply will be indicated by elevated temperature in the glove-box, reduced effectiveness of the moisture adsorbent, and therefore an increase of moisture in the atmosphere, and may also lead to premature circulator failure.

#### 4-8 PHOTOHELIC OPERATION

Operation of the Photohelic involves selecting and setting the high and low glove-box pressure limits. Once these limits are set by the red needles on the gage, pressure will be rigidly maintained by the pressure sensing mechanism in the Photohelic.

The red (pressure sensing) needles and the black knobs which are used to set them, are illustrated in Figure 3-5. The Photohelic permits setting and reading the system pressure to within 1/10" of water pressure.

The Photohelic controls the system pressure at all times when the Pedatrol Power switch is ON.

#### 4-9 FOOT SWITCH OPERATION

The function of the foot switch is to control the position of the gloves in a glove-box. This is accomplished by making slight adjustments in the glove-box pressure relative to the ambient pressure outside the glove-box.

Raising the pressure by depressing the "R" side of the foot switch

will force the gloves outward from the box. Lowering the pressure in the system by depressing the "L" side of the foot switch will cause the gloves to be drawn (retracted) into the glove-box. Foot switch operation is independent of Pedatrol power control. When Pedatrol power is OFF, the foot switch can vary system pressure above or below the limits set on the Photohelic.

#### 4-10 REGENERATION

Regeneration of an operating purifier is performed only when the purifier is no longer maintaining the required atmospheric purity in the system.

#### 4-11 REGENERATION PERIOD

The interval between purifier regenerations is dependent on several factors. Basically, the applicable purifier will have to be regenerated whenever the purity of the glove-box atmosphere falls below that which the system user requires for acceptable operation. Purity measurements are made with instrumentation that monitors those contaminants which are of primary concern to the system user.

#### 4-12 INSTRUMENTATION

Instrumentation is available from Vacuum Atmospheres Company for monitoring the following types of atmospheres:

- Oxygen: A0-315C and A0-316C Oxygen Analyzers
- Nitrogen: AN-1 Nitrogen Analyzer (also Hydrogen)
- Moisture: AM-1 and AM-2 Moisture Analyzers

Vacuum Atmospheres Company will provide information on atmospheric monitoring equipment for other gasses or contaminants on request.

#### 4-13 REGENERATION OPERATION

To initiate regeneration of the contaminated purifier (A for this example) perform the following:

- a. Move the PURIFIER switch to CIRCULATE B (REGENERATE A) position.
- b. Rotate the REGENERATION TIMER knob past START, until the PURIFIER A/REGENERATE LIGHT comes ON.

The process will now perform all of its steps under automatic control of the timer, and the entire sequence takes 12 hours. When regeneration has been completed, the timer will have rotated approximately 360 degrees and will be positioned at STOP.

#### **Note**

The M040-2 is a manually initiated, automatically regenerated system, that does not require monitoring of the regeneration cycle. When this cycle ends, the regenerated purifier is on standby, and ready to perform circulation when the other purifier becomes saturated.

#### 4-14 REPLACING THE PURIFIER CHEMICALS

Under normal, properly controlled operating conditions, the materials inside of either purifier should never have to be replaced. If certain contaminants are introduced into the glove-box, the



oxygen adsorbent capability of the chemicals will be lost. It will then become necessary to replace the contaminated purifier, or remove all the old elements and replace them with fresh, uncontaminated materials. This procedure is explained in Section-7 (Maintenance) with the necessary details.

**Note**

Contaminants which are known to be injurious to the purifier are listed in the CAUTION in paragraph 4-1 of this section. For further purifier information, refer to Section-5 (Theory of Operation).

4-15 SYSTEM PUMP-DOWN

Any time the integrity of the main gas circulation system of the M040 has been broken, such as by the removal of a component in that system, a definite sequence of operations must be performed to restore the system to a state in which it has a purified atmosphere (or an atmosphere which is near enough to the required purity to enable purifier take-over).

This generally means getting the atmosphere down to less than 200 ppm of the applicable contaminant.

**Note**

During all the following operations, monitor the system pressure by observing the compound pressure gage which is located in the rear of the M040 console near the heat exchanger. This gage reads 0 to

30" Hg Vacuum in the counter-clockwise direction and 0 to 30 psig clockwise.

A step-by-step procedure is presented here to be followed whenever "pump-down" is to be performed.

- a. CIRCULATOR OFF.
- b. PHOTOHELIC to OFF.
- c. Close the system circulation valves. (These are the valves on the glove-box, if the M040 is attached to or being used with a VAC-LAB or a DRI-LAB.)
- d. Perform the necessary repair or replacement.
- e. If operating purifier valves (V12A and V13A or V12B and V13B) were closed, OPEN them by placing the PURIFIER switch to either CIRCULATE A or CIRCULATE B as required.
- f. Depress the "L" side of the foot switch; hold it.
- g. While monitoring the compound pressure gage in rear of cabinet, continue to evacuate the system until the gage reads a vacuum of 25" to 30" of mercury.
- h. Depress the "R" side of the foot switch and hold it. This will admit inert system gas into the system's lines. The action is called "back-filling."

**Note**

Continue back filling until the compound gage indicates zero pressure.

**WARNING**

DO NOT PRESSURIZE THE SYSTEM BEYOND 4 PSI AS THIS ACTION MAY RESULT IN SERIOUS DAMAGE.

**WARNING**

DO NOT TURN THE CIRCULATOR ON WHEN NEGATIVE PRESSURE EXISTS IN THE M040 SYSTEM. IT MAY BE PERMANENTLY DAMAGED. THIS WILL VOID THE WARRANTY ON THE CIRCULATOR.

- i. If the glove-box atmospheric purity was not lost (glove-box circulation valves were left closed), open the circulation valves VERY SLOWLY to equalize and back-fill the system.

**Note**

Observe the gloves in the glove-box during the opening of the circulation valves. They will indicate any pressure differential which exists between the box and the M040 system plumbing.

The pressure differential may be adjusted by the use of the foot switch. Do not allow this differential to reach a point, at which the gloves are obviously being stressed to a point where they may fail or be blown off.

- j. When pressure between the glove-box or system and the DRI-TRAIN has become equal, open the valves fully.

- k. Turn the PEDATROL power and CIRCULATOR power ON.
- l. Perform a complete purifier regeneration. Refer to Section 4-13 for the correct procedure.

**Note**

The foot switch applies power to the pressure control valves V1 and V2 independently. The Pedatrol power switch does not affect foot switch operation, and turning off the switch only disables automatic pressure control by the Photohelic device. While the Pedatrol panel power is OFF, pressure may be varied in the positive or negative directions as far as the inert gas or vacuum pump pressures will permit. This feature is used in back-filling, evacuating the system and in leak testing or other types of troubleshooting operations.

**WARNING**

THE (R) FOOT SWITCH IS CAPABLE OF OVERRIDING THE PHOTOHELIC IN THE POSITIVE DIRECTION. DO NOT HOLD THE R-SIDE OF THE FOOT SWITCH DEPRESSED FOR AN EXTENDED PERIOD OF TIME AS PRESSURE WILL BUILD UP INDEFINITELY UNTIL EITHER A COMPONENT FAILURE OCCURS OR THE SUPPLY OF INERT GAS IS EXPENDED.

5-0 THEORY OF OPERATION5-1 GENERAL

The M040 series DRI-TRAINS are designed to control the oxygen and moisture content in the atmosphere of a sealed glove-box. A further DRI-TRAIN function is that of regulating pressure in the glove-box within closely controlled, preset limits. This pressure control is implemented by a Photohelic regulator and a foot switch.

The heart of the DRI-TRAIN system is two chemical purifier canisters, referred to as "purifier-beds." These components contain identical amounts of a moisture absorbent (molecular sieve) and an oxygen reducing agent (Ridox).

The molecular sieve removes moisture (water vapor) from any gas which passes through it.

The Ridox compound is a form of copper which combines chemically with oxygen; thereby removing the oxygen from the gas which is circulated through the compound. Ridox is copper impregnated ceramic in granular form and technically referred to as a "Catalytic Oxygen Remover." It is a highly efficient, regenerable, oxygen absorbent.

When the Ridox is, or becomes, saturated with oxygen, it can be regenerated by a process which uses heat and the recombination of the oxygen with injected hydrogen gas.

Table 5-1 is a list of all major component functions of the M040-2. Further details can be found in the parts list of Section 8.

The regeneration process is manually initiated, then continues under the fully automatic, timed control of the REGENERATION TIMER. The current status of the regeneration cycle is indicated by the position of the timer knob arrow, in relation to the cycle placarding on the control panel.

A heat exchanger is incorporated in the system to remove the heat exchanged by the action of the two-stage circulator blower. The heat exchanger is a water-cooled cylinder which can utilize ordinary tap-water or chilled, recirculated water.

A two-stage circulator blower is used to maintain gas flow through the system.

A vacuum pump furnishes negative (vacuum) pressure which serves three system functions. The pump provides:

- Vacuum source to the glove-box pressure regulating valves.
- Vacuum for evacuation of the applicable purifier during regeneration.
- Vacuum for evacuating the ante-chamber of the glove-box.

## 5-2 PRESSURE CONTROL

### 5-3 THEORY

The DRI-TRAIN gas pressure, under conditions of normal gas circula-

Table 5-1. Major DRI-TRAIN Components

ITEM	SYMBOL	NOMENCLATURE
1	A & B	PURIFIERS - Remove oxygen and moisture from circulated gas in DRI-TRAIN/DRI-LAB system.
2	1B	CIRCULATOR - Maintains circulation of the gas throughout the system.
3	1M	VACUUM PUMP - Provides vacuum pressure for controlling the pressure in the system and for evacuating the gas system and the glove-box antechamber.
4	1TM	REGENERATION TIMER- Times and sequences all steps of the regeneration process.
5	None	HEAT EXCHANGER - Uses water flow to cool the gas leaving the circulator.
6	1PH	PHOTOHELIC - A pressure control device which allows such limits to be preset, and also functions for pressure safety. Provides a gage which enables the pressure to be read and limited to within 1/10" of water.
7	1FS	FOOT SWITCH - Foot operated switch which permits an operator to raise or lower the system pressure while leaving the hands free.
8	1T	An auto-transformer known as a "Boost-Buck" and used in the M040 to enable the customer to use either 208vac or 220vac line power.
9	2T	A step-down transformer which converts 220vac to 115vac for operating all valves and indicators plus the regeneration timer.
10	VI	Solenoid valve. Operated by the Photohelic and the foot switch to apply vacuum pressure to the system.

Table 5-1 (continued)

ITEM	SYMBOL	NOMENCLATURE
11	V2	Solenoid valve. Operated by the Photohelic and foot switch to control the injection of inert gas into the system.
12	V3	Solenoid valve. Used to evacuate the purifier during regeneration.
13	V4	Solenoid valve. Vents the purifier during regeneration cycle and acts as a pressure relief valve at other times. Plumbed in reverse so that it will unseat at about 4 psi.
14	V5A, V5B	Solenoid valves. Used to inject regeneration gas into the applicable purifier.  V5A open and V5B closed - Purifier A being regenerated.  V5B open and V5A closed - Purifier B being regenerated.
15	V6	Solenoid valve. Used to refill the applicable purifier near the end of the regeneration cycle.
16	V7	Solenoid valve. A double valve used to route compressed air to the purifier (being regenerated) inlet and outlet valves, while isolating the on-line purifier.
17	V8A, V8B	Solenoid valves. Select the purifier to be evacuated during regeneration, vents that same purifier during the purging cycle.
18	V12A, V12B	Air operated valves. Gas inlets of Purifiers A and B respectively.
19	V13A, V13B	Air-operated valves. Gas outlets of Purifiers A and B respectively.



tion, is controlled in two ways. It is automatically controlled and held within preset limits by the action of the PHOTOHELIC. This is a device which provides two pressure setting knobs; one which is set to the lower desired pressure limit, and the other to the upper limit. These will be maintained within 1/10" of water at all times.

The second method of controlling the gas pressure in the system is by the use of a foot switch. This switch is used to manually position the gloves in a glove-box or to make other fine changes in the system pressure for any reason. The foot switch permits either increasing or decreasing this pressure.

The Photohelic and the foot switch control the pressure by opening valves (V1, V2) which either admit more gas to the system to increase the pressure, or vent the system to the vacuum manifold (decreasing the pressure).

When the pressure inside the glove-box exceeds the limit set on the left hand red pointer, the Photohelic will close a set of internal contacts. A.C. power (115vac) will then be applied through these contacts to the solenoid of valve V1. This valve will open and apply negative pressure from the vacuum manifold to the main circulation system. Conversely, when system pressure falls below the limit set on the right hand pointer of the Photohelic, another internal contact closure will occur and apply 115vac to the solenoid of valve V2. This action will open V2 and cause "make-up gas"

to be admitted to the gas system. The input will continue until the system gas pressure returns to the allowed operating range.

Valves V1 and V2 can also be operated manually by depressing the proper side of the foot switch which is labelled, (R) and (L). See Figure 3-6. Refer to Figure 5-1 for details of the gas flow routing and valve operations. Figure 5-2 is a schematic of the M040-2 which provides all wiring data.

5-4 PHOTOHELIC

5-5 THEORY

The PHOTOHELIC device is a combination pressure gage and differential pressure switch. The input of the Photohelic is a pressure sensing line connected to a DRI-LAB glove-box or equivalent. This gage is used to determine where system pressure is at any time (relative to the setting of the two red limit needles on its face) as compared to the ambient room pressure.

The output of the Photohelic is in the form of a pair of contact closures.

All M040 units use this device to detect positive and negative pressure points. Therefore, the black needle must, and will be, between the two red pointers at all times.

**Note**

Vacuum Atmospheres Company connects the pressure sensing line to

the Photohelic gas port labelled "Low Pressure", due to using the Photohelic with its other port (High Pressure), vented to free air. This connection results in the LEFT side of the pressure scale reading POSITIVE pressure. Large (+) and (-) decals are placed adjacent to the meter face to eliminate ambiguity.

Relay contacts in the Photohelic are arranged so that when the black needle is to the RIGHT of either red-limit needle, a relay will be actuated.

The Photohelic circuit which actuates the relays, senses the point at which the black needle passes the red one, by the use of photoelectric light detectors that impose no mechanical load on the pointers. This eliminates the possibility of the position (Pressure) detection mechanism loading the needles, and causing an error in the meter reading.

#### 5-6 PURIFIER

#### 5-7 THEORY (Refer to Figure 5-3)

The purpose of the purifier is to remove oxygen and moisture from the gas flowing through controlled atmosphere systems such as a glove-box.

The M040 purifier contains two chemical purification agents. One agent is a molecular sieve which removes moisture from gas flowing through it by a process of molecular absorption. There are two layers (Top and Bottom) of this material in the purifier canisters.

The other agent is called Ridox and is an oxygen absorbent material.

#### 5-8 OXYGEN REMOVAL

Oxygen removal from argon, helium, or nitrogen is accomplished with a reactant (Ridox), a material consisting of finely divided copper on an Alumina Matrix, developed by the Dow Chemical Company. The Ridox operates at ambient temperature and down to  $-80^{\circ}\text{C}$  ( $-112^{\circ}\text{F}$ ). Oxygen removal is possible at space velocities of more than 6,000 volumes of gas/volume of Ridox/hour with little loss of efficiency. Ridox is compatible with molecular sieves in operation and regeneration. This reactant's capacity for oxygen is 2.3 cc  $\text{O}_2$ /gram Ridox. The copper reacts with oxygen to form cuprous or cupric oxide, and oxide is reduced to metallic form by hydrogen at  $150-300^{\circ}\text{C}$  ( $302-572^{\circ}\text{F}$ ) during regeneration. The regeneration product is water. Repeated regeneration does not reduce efficiency of the reactant. Ridox is deactivated by large amounts of  $\text{H}_2\text{O}$  and other compounds containing reduced sulfur.

#### 5-9 WATER REMOVAL

Water is removed by a molecular sieve enclosed in the same container as the oxygen reactant. Molecular sieve and Ridox both operate at ambient temperature and are regenerated by the same process. Also removed by the sieve at ambient temperature are carbon dioxide, sulfur dioxide, nitrogen dioxide, hydrogen sulfide, carbon monoxide and many organic compounds including: alcohols, aromatics, amines, halogenated compounds, oxygenated compounds,

hydrocarbons and organic acids. Inorganic acids are removed but the sieve is poisoned and cannot be regenerated. Under normal circumstances it is regenerated at temperatures of 205-593°C (400-1100°F) while purging with dry gas, followed by evacuation. The capacity of the sieve for water is 0.031 gm H<sub>2</sub>O/gm sieve at a bed temperature of 27°C (80°F), and increases as the bed temperature is reduced. At a bed temperature of 5°C (40°F), capacity is increased to 0.080 gm H<sub>2</sub>O/gm sieve.

5-10 PROPERTIES OF THE GAS RECIRCULATION SYSTEM

5-11 SYSTEM REQUIREMENTS

The gas purification system required is determined by the rate at which impurities are admitted to the atmosphere and by which of these impurities are to be removed.

5-12 ESTIMATING THE LEAKAGE RATES

An approximate rate of contamination can be determined from:

- manufacturer's data on moisture diffusion through gloves (Neorpene, less than 0.8 gm/day/pair; Butyl, 0.08 gm/day/pair for 30 mil thickness);
- the oxygen and water content of the inert gas used to adjust pressure and replace the gas lost through use of the ante-chamber (5 ppm O<sub>2</sub>, 11 ppm H<sub>2</sub>O, using commercial grade argon);
- manufacturer's data on glove-box leak rate (less than 1x10<sup>-5</sup>cc second air at 8" w.c. in VAC DRI-LABS);

- contamination resulting from operations within the box.

### 5-13 CONTAMINATION

In most systems, the largest amount of contamination is due to leaks in the enclosure and its associated plumbing. These leaks can be reduced considerably by helium leak checking the system. Contamination from box operations can be minimized if the operator is careful in using the ante-chamber and in avoiding damage to the gloves. The leak rate will affect:

- a. the equilibrium interval between regenerations;
- b. the rate of recovery from a high level of contamination.

### 5-14 CIRCULATION RATE

The circulation rate required is determined by the leak rate (affecting equilibrium ppm) and by the box volume (affecting rate of recovery).

### 5-15 VOLUME

The box volume required is dependent on the operations to be performed and will determine such system requirements as circulation rate and purifier capacity.

### 5-16 RECOVERY TIME

The time required for recovery from a high ppm range to less than 1 ppm is directly proportional to box volume, inversely proportional to circulation rate, and is approximately proportional to the natural log of the initial concentration. As the purifier reactant

becomes saturated with contaminants, efficiency is lost and regeneration is required. The level of efficiency that can be tolerated before regeneration is required depends on:

- the leak rate; and
- the recovery rate desired.

#### 5-17 REGENERATION INTERVAL

The regeneration interval depends on the rate at which impurities are admitted to the enclosure.

#### 5-18 LEVELS OF PURITY ATTAINABLE

In most cases it is practical to attain less than 1 ppm of oxygen and water. Lower levels are possible when care is taken in eliminating sources of contamination.

#### 5-19 PURIFIER CONSTRUCTION

The M040 purifier is constructed (see Figure 5-3) so that in normal operation the gas to be purified enters the port which opens into the lower plenum of the canister. Gas flows from this lower plenum up through the three layers of chemicals, into the upper plenum, and then up through the outlet pipe where it is returned to the main gas circulation system. "Regeneration Gas" flow is in the reverse direction.

#### 5-20 CHEMICALS

The chemicals in the M040 system are capable of use and regeneration over a period of many years, but these chemicals can be

rendered useless by contamination from various poisonous substances. Observe the WARNING on pages 4-1 and 4-2.

5-21 REGENERATION

5-22 THEORY (Refer to Figure 5-4)

To restore the purification capability of the purifier, two general actions must take place:

- The moisture trapped by the molecular sieve must be removed completely.
- The oxygen must be removed from the copper oxides and the copper returned to essentially pure form.

The removal of moisture is accomplished by heating the purifier to a temperature which causes the moisture to become vaporized and then passing dry gas through the molecular sieve to carry away the water vapor.

The restoration of the Ridox involves a chemical process wherein a hydrogen rich gas is passed through the Ridox to create a chemical reaction in which the hydrogen combines with the oxygen in the copper oxides and reduces them to pure copper, with water ( $H_2O$ ) as the by-product. The  $H_2O$  will be in "water-vapor" form due to the presence of high heat, and will be swept away by the passage of the inert gas through the purifier.

5-23 REGENERATION/FORMING GAS

A gas which is from 3 to 10 percent hydrogen is used during regeneration and known as regeneration gas.



The inlet and outlet valves (V12A and V13A or V12B and V13B), between the purifier (A or B) and the main circulation system, are closed at the beginning of the regeneration cycle. Valve V5A or V5B opens, to allow regeneration gas to flow directly into and through the purifier.

The gas is applied to the applicable purifier and adjusted to achieve a flow rate of one cubic foot per minute. The rate is set at the time of installation by adjusting the gas tank pressure while observing a flow meter. This flow rate ensures that an adequate amount of hydrogen is present in the Ridox during the "PURGE" portion of the REGENERATION cycle, thus securing the chemical reduction of the Ridox compound.

#### 5-24 REGENERATION-PRELIMINARY CONDITIONS

Prior to placing the Regeneration-timer in START, check for an adequate supply of regeneration gas.

#### **Note**

It is well to note here the major difference between the (-1) and the (-2) versions of the M040 systems. The M040-1 system does not circulate gas and does not perform any purification of the glove-box atmosphere during the regeneration operation. The M040-2 system embodies two purifier beds. When one purifier is placed in the regeneration mode, the other is on-line and atmospheric purification goes on as usual. The advantages of the two-purifier, M040-2 units, are quite evident. It need never be "off-line."

5-25 REGENERATION OPERATION SEQUENCE-GENERAL5-26 GENERAL

The sequence of activities which take place during the regeneration cycle are graphically illustrated in Figure 5-4. The programming of the regeneration sequence is accomplished through the application of a motor-driven timer which sequentially programs a set of five cams. These cams open and close five sets of electrical contacts which in turn operate valves, relays, lights and the timer motor.

The regeneration cycle is manually initiated by rotating the REGENERATION TIMER (R.T.) knob from its "STOP" position toward "START" position until the REGENERATE A or REGENERATE B light comes on. Reference to Figure 5-4 will show that moving the knob 10 degrees will apply power to the timer motor through contacts associated with cam number one. This cam also turns ON the REGENERATE A or REGENERATE B light.

5-27 AUTOMATIC SEQUENCE

Once the timer knob has been rotated 10 degrees to "START", the regeneration operation will proceed automatically through each step. After 12 hours it will have completed all the operations necessary for purifier regeneration. At the end of the 12 hours, the timer knob pointer will come to rest at the position labelled "STOP."

The regenerated purifier is on standby, and ready to circulate when

the other purifier becomes saturated.

#### 5-28 DETAILS

Refer to Figure 5-4. This diagram, along with the schematic of Figure 5-2, indicates that several electrical and pneumatic components are involved in the automatic sequence. These components are:

- Timer motor. (Cam-1)
- REGENERATE A or REGENERATE B light (red). (Cam-1)
- Purifier heater (Cam-2)
- Purge and vent valves (V4, V5A or V5B). (Cam 3)
- Purifier evacuation valve (Vacuum valve-V3). (Cam-4)
- Purifier refill valve (V6). (Cam-5)

All of these components are directly controlled by the Regeneration Timer. Fuse 3F supplies all power to the timer and to those items controlled by it.

The one exception to this is the purifier heater. When the switch (3S) is placed in "REGENERATE A" or "REGENERATE B", 220vac power is placed on the normally-open contacts of relay 1CR. These contacts are closed by Cam-2 of the timer.

#### 5-29 TIMER CAMS (Figure 5-4)

There are five cams driven by the timer motor, and these cams sequence all the regeneration operations. Each one closes its associated contacts for a specific number of degrees of timer shaft rotation. This cam activation period is expressed in both time and degrees of shaft rotation (indicated in Figure 5-4).

A discussion of each cam and its relationship to the individual cam's resulting operation(s) follows.

5-30

CAM-1

This cam performs two parallel functions. It energizes its contacts after the timer knob has been manually rotated to the "START" position (approximately 10 degrees of shaft rotation). Cam-1's basic function is to energize the electric motor which will continuously rotate the timer through the remaining 350 degrees of required shaft rotation. It will also de-energize the motor after 350 degrees (12 hours) of travel.

The REGENERATE A or REGENERATE B light on the control panel is connected directly in parallel with the motor and will thus be "ON" whenever the timer motor is energized.

5-31

CAM-2

Closes its contacts at the point (START position) where Cam-1 energizes the timer motor and light. Cam-2 holds its contacts closed for 104 degrees or 3.5 hours.

During this time, a calrod heater inside the applicable purifier is energized. The heat is applied to this purifier at about 200°C for 3.5 hours during which time the heat activates/accelerates the physical and chemical reactions attendant to the purification process. It also converts moisture trapped by the molecular sieve into water vapor. The absorbed moisture (in vapor form) is removed by the passage of purge gas through the purifier being regenerated.

5-32

CAM-3

During the last 0.8 hours (48 minutes) of the heating period, this cam's contacts are closed.

Two solenoid valves are actuated by Cam-3.

- Valve V4 vents the purifier to free air.
- Valve V5A or V5B opens to admit the hydrogen-rich regeneration gas which will combine with the copper oxides and restore them to pure copper plus water.

The presence of heat will cause the water to exist in vapor form. Regeneration gas also flows through the purifier at a rate of 1 CFM, and this flow is adequate to carry-off the trapped water vapor and discharge it into the external atmosphere.

5-33

CAM-4

Twenty-two minutes (11 degrees of shaft rotation) after the heater goes off and the purge and vent valves have closed, the evacuation portion begins. Solenoid valve V3 is energized and connects the purifier to the vacuum manifold. The vacuum pump will now spend 2.7 hours (80 degrees of rotation) removing all gas and moisture from the purifier.

The vacuum solenoid valve, V3, will close again at about seven hours after the start of the regeneration cycle, at which time the purifier will still be evacuated and nearly free of any moisture.

5-34 CAM-5

After the gas and moisture have been removed from the purifier, it is necessary to refill it with dry, inert gas of the same composition as that now in the glove-box. At 205 degrees of timer rotation (about seven hours into the regeneration cycle), valve V6 opens and allows system gas to begin refilling the purifier. A period of 4.9 hours is allowed for the purifier to cool.

5-35 TERMINATION

Cam-5 will deenergize V6 after 4.9 hours or 352 degrees of timer rotation. Eight degrees later, at 360 degrees, Cam-1 will also deenergize the timer motor and REGENERATION A or B Light, signaling the end of the regeneration operation. e

5-36 CIRCULATOR

The M040 uses a two-stage Rotron gas circulation blower with a 40 CFM capacity, and one that is oil-free and hermetically sealed. This unit has integral thermal overload protection, but should not be run continuously with the circulation valves closed. The circulator requires 230vac, is controlled by the CIRCULATOR switch (4S).

5-37 VACUUM PUMP

A two-stage 3.5 cfm pump or equivalent, runs continuously whenever the DRI-TRAIN power switch is ON, and may be stopped for troubleshooting by unplugging the power cord at the back of the control

chassis. The vacuum pump is used to evacuate the applicable purifier during regeneration, and may be plumbed to evacuate the ante-chamber when installing materials into the glove-box. It is also used by the Photohelic and foot switch to control and maintain the pressure in the glove-box.

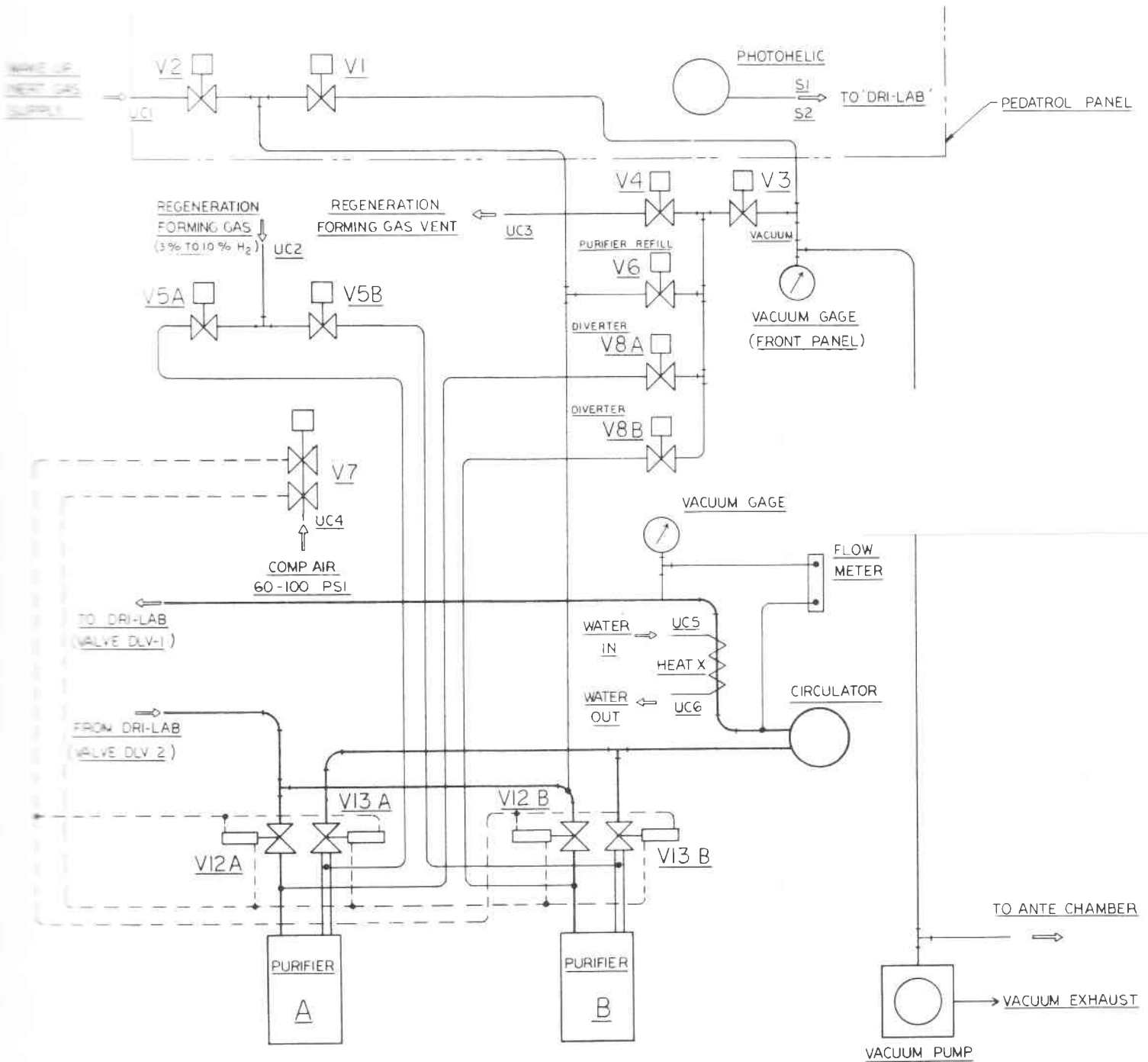

Figure 5-1. M040-2 Gas Flow Diagram



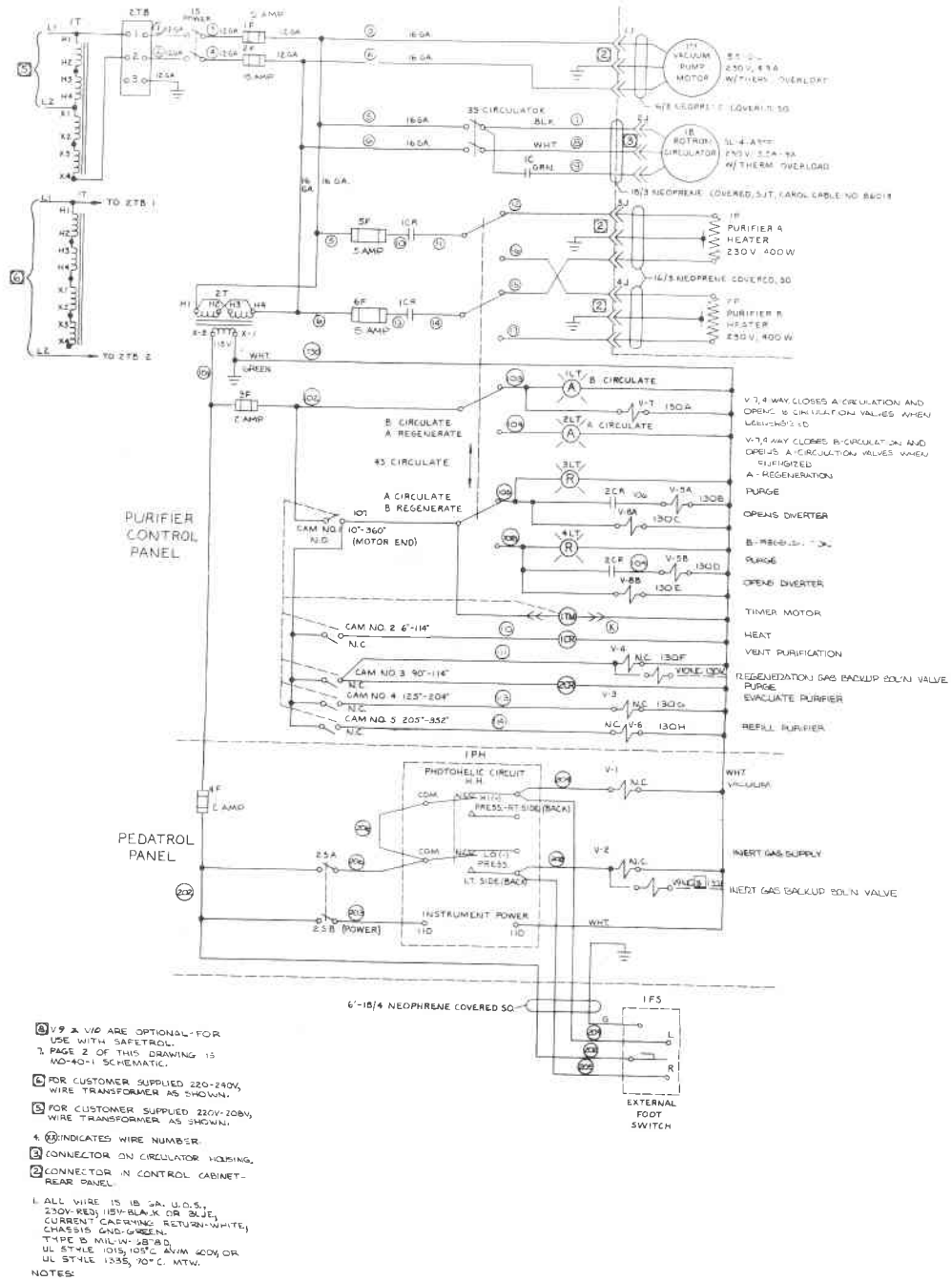
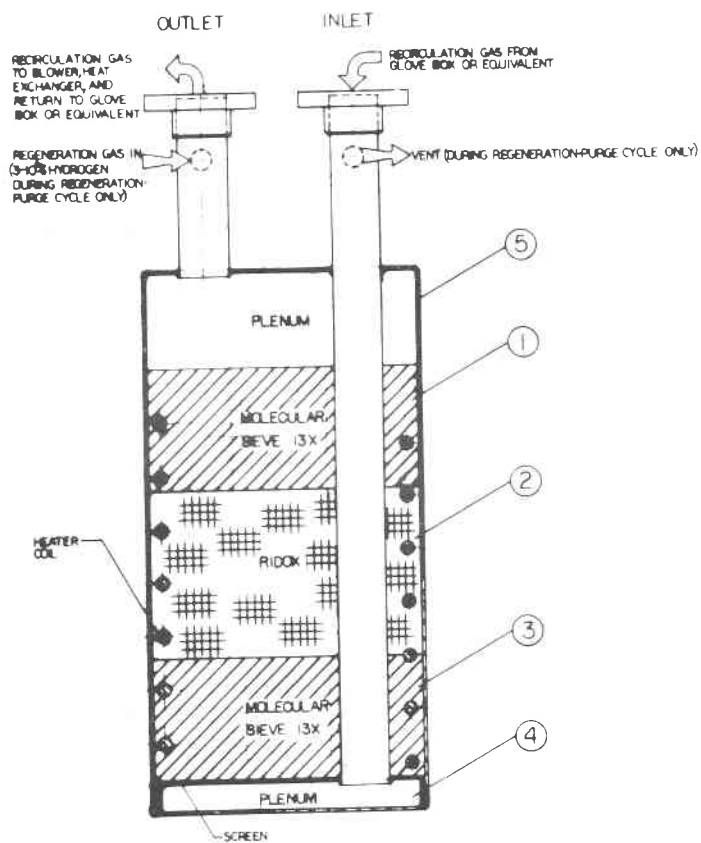
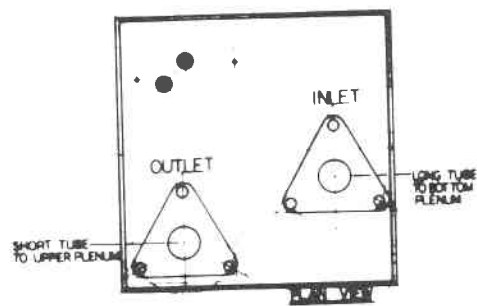

Figure 5-2. MO40-2 Schematic Diagram



## NOTES -

- ① - 10 LBS OF MOLECULAR SIEVE - TYPE 13X FILLED TO 2.5" FROM TOP
- ② - 10 LBS OF RIDOX
- ③ - 8 LBS OF MOLECULAR SIEVE - TYPE 13X
- ④ - PLENUM - NO MATERIAL TO BE SEEN IN BOTTOM PLENUM WHEN VIEWED THRU OUTLET PORT
- ⑤ - HANDLE AND STORE IN UPRIGHT POSITION

Figure 5-3. M040 Purifier Cross Section

M040-2-11/78

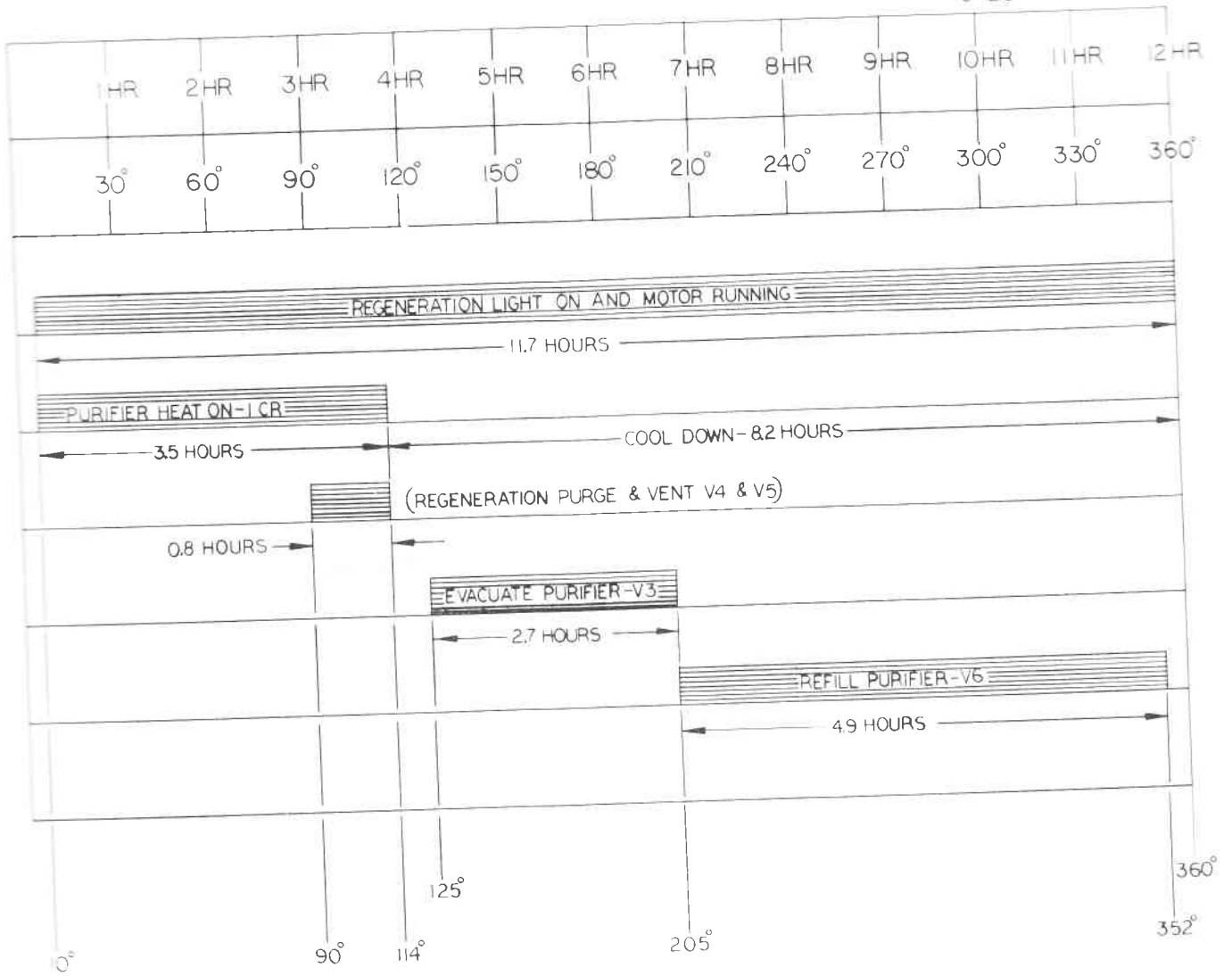

- CAM-1 10°-360°=11.7 HOURS MOTOR RUNNING & LIGHT ON
- CAM-2 10°-114°= 3.5 HOURS PURIFIER HEAT ON (RELAY ICR)
- CAM-3 90°-114°= 0.8 HOURS PURGE PURIFIER (VALVE V-5A)
- CAM-4 125°-204°=2.7 HOURS EVACUATE PURIFIER (VALVE V-3)
- CAM-5 205°-352°=4.9 HOURS REFILL PURIFIER (VALVE V-6)

360° EQUALS 12 HOURS  
 30° EQUALS 1 HOUR  
 0.5° EQUALS 1 MINUTE

Figure 5-4. Regeneration Timing Diagram

6-0 TROUBLESHOOTING6-1 GENERAL

Due to extensive application of high reliability components with low failure rates, troubleshooting problems in the DRI-TRAIN are a rare occurrence.

This section will present a brief discussion of an approach to use for isolating any system gas leaks which might occur to a general area of the circulation system. A tabulation of those symptoms of failure which, if they occurred, would most likely be associated with some specific component of the system is also presented, and a brief, general example of a proposed method of troubleshooting a hypothetical failure of a valve also appears in Section 6. This valve and its imaginary failure were selected at random only for the purpose of providing the example. Valve failures are rare in the M040-2.

6-2 VACUUM PUMP

Failure of the vacuum pump is readily evidenced by a loss of system vacuum or by noting the vacuum gage reading. The audible sound of the pump is one further indication.

6-3 CIRCULATOR

The circulator blower, like the other DRI-TRAIN components, has a long, trouble-free history. If a system pressure loss is noted; and if it is determined that the circulator is not running - check

the following items:

- System gas temperature.

There is a thermal overload cutout in the circulator which will be tripped in the event of an overheat condition. It will automatically reset when the circulator cools.

- Power to the circulator flows through switch (3S) and is overload-protected by 15 amp fuses 1F and 2F.

### Note

If an overheat condition occurs in the gas flowing in the main circulation lines, check the water supply to the heat exchanger. This should be cool water (typically 20°F below the desired glove-box atmospheric temperature), flowing at a rate of 1 gpm, minimum.

### WARNING

DO NOT ALLOW THE CIRCULATOR SWITCH TO BE ON AT ANY TIME WHEN ANY OF THE SYSTEM'S MAIN CIRCULATION VALVES ARE CLOSED.

6-4

### PHOTOHELIC

Photohelic failures are rare also. The most common failure is a lamp failure resulting in non-operation of the setpoints. The only other foreseeable problems would result from mishandling of the pressure setting knobs, or broken wires to screw terminals on the rear of the instrument.

**WARNING**

ALWAYS BE CERTAIN THAT THE PEDATROL POWER IS OFF WHEN ANY OF THE FOLLOWING CONDITIONS EXIST:

- VACUUM PUMP IS NOT RUNNING.
- INERT GAS SUPPLY IS NOT ABLE TO PROVIDE MAKE-UP GAS TO THE SYSTEM FOR ANY REASON.
- SYSTEM CIRCULATION VALVES (DLV-1 AND DLV-2) ARE CLOSED.
- VALVES V1 AND/OR V2 ARE NOT FUNCTIONING PROPERLY.
- THE MAIN GAS CIRCULATION SYSTEM IS TO BE VENTED TO THE EXTERIOR ATMOSPHERE FOR ANY LENGTH OF TIME AND FOR ANY REASON.

**WARNING**

THE OPEN PORT ON THE REAR OF THE PHOTOHELIC MARKED HIGH PRESSURE MUST BE FREE OF ANY OBSTRUCTION AT ALL TIMES.

6-5 SOLENOID VALVES

Proper operation of the solenoid valves is verified by testing for the presence of a magnetic field around the body of the solenoid. This is done by placing a small magnet near the red cap on the

solenoid. When the solenoid is energized, the magnet will be strongly attracted to the center core and the 60 cycle "hum" in the coil will be felt in the magnet.

Reference to Figure 5-2 will provide all necessary information on how to energize any given solenoid when so desired. No attempt will be made here to explain the basic procedures normal to tracing the flow of electrical current in the M040. The schematic provided in Section-5 of this manual is straight-forward and a basic knowledge of electrical troubleshooting is credited to anyone authorized to attempt any kind of trouble analysis in the M040. A tabulation (Table 6-1) of all the gas valves and those evident symptoms which might logically point to a failure of the valve to energize is provided.

In the event of a solenoid valve failure, check the electrical operation first. If the valve is/has been energized, but the failure symptom persists, it may become necessary to disconnect the valve from its plumbing to determine whether or not it is mechanically defective.

If the solenoid is found to be defective, this component may be easily replaced by disconnecting its leads from their terminal strip and removing the red plastic retaining cap.

In the event that a new solenoid is to be installed, it may be necessary to splice wires onto the pigtail leads attached to the

Table 6-1. Solenoid Valve Failure Indications

Valve	Failure Indication
V1	<p data-bbox="427 546 639 580"><u>FAILS TO OPEN</u></p> <ul data-bbox="427 611 1331 837" style="list-style-type: none"> <li data-bbox="427 611 1331 707">- Pressure increases in the system beyond the Photohelic's preset limits.</li> <li data-bbox="427 736 1118 770">- V4 starts relieving pressure at 4 psi.</li> <li data-bbox="427 799 1331 837">- Gloves (if applicable) will rupture before 4 psi.</li> </ul> <p data-bbox="427 902 799 936"><u>FAILS TO CLOSE OR LEAKS</u></p> <ul data-bbox="427 965 1331 1375" style="list-style-type: none"> <li data-bbox="427 965 1331 1061">- Pressure cannot build-up in the system - vacuum may reach a negative pressure beyond the preset limits.</li> <li data-bbox="427 1090 1331 1187">- Photohelic will indicate a negative pressure or it will be holding the inert gas valve (V2) open.</li> <li data-bbox="427 1216 1331 1312">- Excessive amount of inert gas is being used due to gas being removed through valve V1.</li> <li data-bbox="427 1341 1150 1375">- gloves are retracted into the glove-box.</li> </ul>
V2	<p data-bbox="427 1570 639 1603"><u>FAILS TO OPEN</u></p> <ul data-bbox="427 1635 1331 1852" style="list-style-type: none"> <li data-bbox="427 1635 1331 1731">- Pressure cannot be increased in the system when the R-side of the foot switch is depressed.</li> <li data-bbox="427 1760 1331 1852">- Pressure remains low and gloves retract into the glove-box.</li> </ul>



Table 6-1 (continued)

	<p><u>FAILS TO CLOSE</u></p> <ul style="list-style-type: none"> <li>- Pressure in the system rises out of control. The vacuum system (via valve V1) may or may not be able to offset the effect of the inert gas entering the system, depending on the position of the open valve V2 and the amount of the gas flowing through the leak.</li> <li>- The gloves extend radically.</li> <li>- V4 will start venting off gas at 4 psi.</li> </ul>
V3	<p><u>FAILS TO OPEN</u></p> <ul style="list-style-type: none"> <li>- Regeneration failure will occur.</li> </ul>

**Note**

"REGENERATION FAILURE" is a term which means that after the completion of a full REGENERATION cycle (12 hours including cooling time), the purity of the system atmosphere cannot be maintained: the moisture and oxygen were not removed from the saturated purifier. Thus, the purifier is unable to remove oxygen and moisture from the gas circulating through it.

	<ul style="list-style-type: none"> <li>- The purifier will not be evacuated during the re-generation cycle and the waste products generated</li> </ul>
--	--

Table 6-1 (continued - 2)

	<p>as moisture during the earlier portions of the cycle will not be removed.</p> <ul style="list-style-type: none"> <li>- The purifier remains saturated with moisture.</li> </ul>
	<p><u>FAILS TO CLOSE</u></p> <ul style="list-style-type: none"> <li>- Positive pressure cannot be established in the system.</li> <li>- Same symptoms as "V1 FAILURE TO CLOSE."</li> </ul>
V4	<p><u>FAILS TO OPEN</u></p> <ul style="list-style-type: none"> <li>- Purge portion of the regeneration operation will not occur. Moisture will <u>not</u> be purged out of the saturated molecular sieve and the conversion of the saturated Radox will not occur.</li> <li>- "REGENERATION FAILURE" occurs.</li> <li>- If the valve "freezes" in the fully closed position, excess pressure might build up in the purifier during heating.</li> <li>- Purifier may overheat and damage charge if there is no flow during regeneration.</li> </ul>
	<p><u>FAILS TO CLOSE</u></p> <ul style="list-style-type: none"> <li>- Entire DRI-TRAIN system would be continuously vented</li> </ul>

Table 6-1 (continued - 3)

	<p>to the outside atmosphere. Pressure would never build up.</p> <ul style="list-style-type: none"> <li>- "REGENERATION FAILURE" will occur.</li> </ul>
V5A or V5B	<p><u>FAILS TO OPEN</u></p> <ul style="list-style-type: none"> <li>- "REGENERATION FAILURE" occurs.</li> </ul> <p>Purifier will not be purged of moisture during an attempted regeneration.</p>
	<p><u>FAILS TO CLOSE</u></p> <ul style="list-style-type: none"> <li>- "REGENERATION FAILURE" occurs.</li> <li>- The regeneration gas will be expended due to the vacuum pump drawing away all the gas through V3 during the EVACUATION cycle. (See Figure 5-4)</li> </ul>
V6	<p><u>FAILS TO OPEN</u></p> <ul style="list-style-type: none"> <li>- The purifier will not be refilled from the system and will <u>remain evacuated</u>.</li> <li>- The pressure will not be equalized between the purifier and the system at the end of the regeneration cycle.</li> <li>- Cooling is slowed.</li> </ul>

Table 6-1 (continued - 4)

	<p><u>FAILS TO CLOSE</u></p> <ul style="list-style-type: none"> <li>- "REGENERATION FAILURE" will occur.</li> </ul>
V7	<p>This is a double valve, and has no failure history. If it were to fail, V7 would most likely not energize (thereby remaining deenergized). The purifier (B) valves V12B and V13B could not be closed.</p> <ul style="list-style-type: none"> <li>- REGENERATION FAILURE would result.</li> </ul>
V8A and V8B	<ul style="list-style-type: none"> <li>- FAIL(S) TO OPEN. Unit would not get complete regeneration (no evacuation, no purge, no refill).</li> <li>- FAIL(S) TO CLOSE When the other unit begins to evacuate, pressure changes are evident in the glove-box, and there is introduction of regeneration gas into the box.</li> <li>- LEAK Pressure changes would be noted, and there would be purge gaps.</li> </ul>

Table 6-1 (continued - 5)

V12A	These valves normally function in parallel. A failure
and	of either or both of these valves (V12A and V13A or V12B
V13A	V13B) would prevent the applicable purifier from being
or	regenerated. If these valves failed, the following would
V12B	occur when regeneration was attempted:
and	
V13B	
	- System gas would heat up and expand during the HEAT
	cycle.
	- All purge gas would be lost, heated and allowed to
	fill-up the entire circulation system. It would
	not be contained within the purifier.
	- The vacuum pump would attempt to evacuate the
	entire circulation system during the EVACUATION
	cycle.
	- "REGENERATION FAILURE" would occur.

replacement solenoid. It is strongly recommended that the electrician use pre-insulated splices of the STAKON type.

If the solenoid and its related circuitry are not at fault and a mechanical failure is indicated, refer to Table 6-1 as a means of verifying the symptom of valve failure.

#### 6-6 AIR-OPERATED VALVES (Figure 6-1)

These valves (V12A, V13A, and V12B, V13B) are positioned by applying compressed air to either the "OPEN" or "CLOSE" ports on the air-driven cylinder. System solenoid valve, V7, is used to route the compressed air to the valves and is electrically operated by the PURIFIER switch (3S). One pair of the above air-operated valves is normally closed, and the other pair normally open (depending on whether V7 solenoid is energized or deenergized). The V7 normally routes compressed air to the OPEN ports of the pair of valves, whose purifier is in the CIRCULATION mode.

#### **Note**

If valves V12A and V13A or V12B and V13B are not actuated during an extended period of time, the lubricant in the air cylinder (combined with any impurities which it may have collected from the compressed air) may become stiff enough to interfere with - or prevent - the operation of the air cylinder and the valves.

If this occurs, it will be necessary to disassemble and clean the valves. The repair work is described in Section-7 (Maintenance) of this manual.

The action - or lack of it - of the air-valves can be determined visually by moving the Purifier switch (3S) from CIRCULATE A to CIRCULATE B (or REGENERATE B to REGENERATE A), and noting the rotation of the shaft and its coupling, which are between the air-cylinder and the body of the valve. (Figure 6-2)

#### 6-7 REGENERATION TIMER

(Refer to Figures 5-2, 5-4, 6-2, and 6-3)

The most obvious symptom of failure of the timer would be a failure of the unit to progress from the START to HEAT position. This would indicate that the built-in motor is not running.

If the REGENERATE A or REGENERATE B light is on, power is available at the timer because this light is operated through the contacts of cam switch number one. This light is in direct electrical parallel with the windings of the motor. (Refer to schematic of Figure 5-2)

If the REGENERATE A or REGENERATE B light is on, and the timer's motor is not running, follow this procedure:

- a. Listen to the sound of the motor to determine whether or not electrical power is attempting to drive it.
2. Use an A.C. voltmeter to check for 115 vac at a point on

the input leads, close as possible to the motor. The most convenient point is the contact (N.O.) of cam switch-1 on the terminal block on the rear of the timer. (See Figure 6-2)

- c. If power is present at the motor and it still does not run, replace the entire REGENERATION TIMER assembly.
- d. If voltage is not present at the motor, trace back through the cam switch, purifier switch, and fuse 3F, to the transformer (2T), to determine the point at which the circuit is broken, and repair or replace accordingly.

#### 6-8 PRESSURE PROBLEMS - GENERAL

##### **Note**

Conditions relative to loss of pressure or vacuum in the portions of a system which are not a part of the DRI-TRAIN, as delivered, will not be discussed here as they are covered in manuals supplied with the associated units. When a loss of system pressure has been discovered, it becomes necessary to break-down that discovery into more clearly defined categories as a means of expediting the final location and correction of the problem.

#### 6-9 PROBLEM CATEGORIES

A loss of pressure - positive or negative - should be identified and placed into one of these general categories prior to proceeding further:

- a. An internal problem which does not result in contamina-



tion of the atmosphere within the DRI-TRAIN circulating gas system.

- b. Problems which are causing "outside" air to enter and contaminate the system.

The problems of group (a) above may be further divided into these sub-groups:

- a-1. Gas is being added to the system - when it shouldn't be - through malfunctioning valves.
- a-2. Gas is being exhausted from the system - and perhaps being replaced - but no outside (contaminated) air is being admitted to replace the lost gas.

Group (b) above subdivides into these types of problems:

- b-1. Air entering the system through an operating faulty valve.
- b-2. Air entering through any kind of a break in the plumbing, valves, etc. A breach in the system's hermetic seal.

The problems of detecting, identifying, and isolating these four basic categories of problems and correcting them cannot be fully exhausted here. An effort will be made to impart sufficient knowledge of each group to enable a reasonably capable technician to satisfactorily resolve most problems. Factory assistance is available if - on a rare occasion - a problem should occur which cannot be resolved locally.

6-10 CATEGORY (A-1)

Gas is entering the system illegally. No outside leak - a valve is at fault.

The related symptoms are:

1. Pressure continues to rise and the Photohelic attempts to relieve the pressure by opening valve V1 for extra-long periods of time.
2. Valve V4 (installed in reverse to function as a pressure relief valve at 4 psi) venting gas excessively.
3. If a glove-box is part of the system, the gloves are distended and the foot switch or Photohelic may or may not be able to retract or soften them.

6-11 CATEGORY (A-2)

Gas is being exhausted and not replaced.

A passage of gas to and from the outside air is not indicated as the gas is only going out of the system. This indicates that a valve is letting gas out to the external atmosphere only.

Valves V1, V3 and V4 are all possible sources for this type of leak.

Valves V1 and V3 could, if malfunctioning, allow gas to leave the system by way of the vacuum manifold, vacuum pump, and its exhaust.

Valve V4 is a relief valve which vents to outside air, and should vent only at pressures about 4 psi.

6-12 CATEGORY (B-1)

Air or gas entering the system improperly: no hermetic seal rupture in the system. Air or gas is entering through a valve or valves.

The following valves, if faulty, could admit gas into the system:

- V2 - Inert (Make-up) gas.
- V5A or V5B - Regeneration forming gas.

**WARNING**

DO NOT LEAK CHECK THE DRI-TRAIN USING HALOGEN LEAK TESTS OR EQUIPMENT AS CONTAMINATION AND DESTRUCTION OF THE PURIFIER'S CHEMICAL CHARGE WILL RESULT. IT WILL ALSO BE EXTREMELY DIFFICULT TO EVACUATE THE HALOGEN GAS AND TO RE-ESTABLISH A PURE ATMOSPHERE.

6-13 CATEGORY (B-2)

This type of leak is the most difficult to locate - if it is one of small volume. Finding plumbing leaks is generally a matter of increasing system pressure and employing any or all of the several available methods for detection. Some of these are presented here.

6-14 HELIUM LEAK TESTING

This is a convenient method which will locate small leaks in a confined area. It makes use of a "Helium mass-spectrometer" equipped with a "SNIFFER."

Helium testing for leaks in the DRI-TRAIN will involve these steps:

- a. Isolate the DRI-TRAIN from all external systems (LAB, VAC-LAB, etc.). Close valves DLV-1 and [ the DRI-LAB and/or the equivalent isolation valves on other units.
- b. Turn OFF the CIRCULATOR switch.
- c. Turn OFF the PEDATROL power switch. (Disables the automatic pressure control system.)
- d. Disconnect the INERT GAS supply from the utility panel.
- e. Connect a source of Helium gas to the inert gas connection on the utility strip.
- f. Disconnect and cap-off the REGENERATION FORMING GAS port on the utility strip.
- g. Evacuate the entire system of all gas, using the foot switch. Monitor this operation by observing the vacuum gage inside the back of the cabinet.

**Note**

While the system circulation valves (DLV-1 and DLV-2) are closed, the Photohelic gage is not reading DRI-TRAIN pressure. It is reading glove-box or external system pressure only.

- h. Depress and hold the L-side of the foot switch until the vacuum gage in the rear of the cabinet reads a maximum negative (Vacuum) pressure. Release the foot switch.

**Note**

This evacuates all gas from the DRI-TRAIN prior to refilling with Helium gas for testing.

**WARNING**

WHEN PRESSURIZING THE M040 SYSTEMS, NEVER CREATE A POSITIVE PRESSURE GREATER THAN 4 PSI. PRESSURES ABOVE THIS LEVEL WILL RESULT IN SEVERE DAMAGE TO COMPONENTS OF THE M040. USE OF A PRESSURE LIMITING REGULATOR ON THE HELIUM GAS SOURCE IS STRONGLY ADVISED. OVER-PRESSURIZING WILL VOID THE WARRANTY!

- i. Refill the system with Helium by depressing the R-side of the foot switch. Do not exceed 4 psi.
- j. Use the Helium leak detector with a "sniffer" probe to locate the point at which gas is escaping.

**Note**

Probe every joint, valve, gage, etc. in the M040 until it is established that the actual source of gas leakage has been found and that no other leaks exist.

k. When the problem has been isolated to one component and the course of required repair has been determined, proceed as follows:

- Remove or shut-off the Helium gas source.
- Bleed off the Helium trapped in the system. Vent the system to atmospheric pressure.

**Note**

If the leak was located in a portion of the system other than in the purifier(s) or the plumbing and valves V12A, V13A, V12B, V13B, it will be wise to isolate the applicable purifier from the system, prior to venting the system to the outside atmosphere. This will prevent contamination of the above purifier and prolong the period between regenerations. Isolation is an arbitrary matter and depends on the current status of the purifier, where the malfunction occurred, and other unforeseeable circumstances.

- Remove and replace, or repair as required, and reinstall any parts removed for any reason.
- Visually check the entire system for mechanical

integrity.

- Reconnect the source of Helium to the inert gas input at the utility strip.
  - Check to be certain that the Pedatrol and the Circulator are turned OFF.
  - Using the R-foot switch, re-pressurize the system. Do not exceed 4 psi.
- l. Leak check the system again making certain that the repairs were effective in removing all leaks.
  - m. Vent the system and remove the Helium gas source. Reconnect the inert gas supply.
  - n. Evacuate the system completely by depressing and holding the L-side of the foot switch. Evacuate as far as possible while monitoring the vacuum gage inside the console.
  - o. Refill the system with inert gas by depressing the R-side of the foot switch. Pressurize the system to atmospheric or zero pressure on the pressure gage inside of the cabinet.
  - p. Equalize the pressure between the DRI-TRAIN system and the glove-box (or any other external system) by very slowly opening the system isolation, or circulation valves.
  - q. When pressure has been equalized and the circulation valves are fully open:

- Turn ON the pedatrol power.
- Turn ON the Circulator.

**Note**

The DRI-TRAIN should now be in fully operational condition.

**Note**

In the event the regeneration process becomes suspect (i.e., the atmospheric purity cannot be maintained even though the purifier has been regenerated), check the purifier heater to be sure it is, in fact, getting hot. This can be accomplished by touching the purifier; it should feel quite warm to the touch at the end of the HEAT portion of the regeneration cycle.

Also, check the continuity of the two fuses (5F and 6F) which protect the purifier heater.

These fuses are located on the front of the DRI-TRAIN panel. See Figure 3-1, Section 3 (Initial Set-Up).



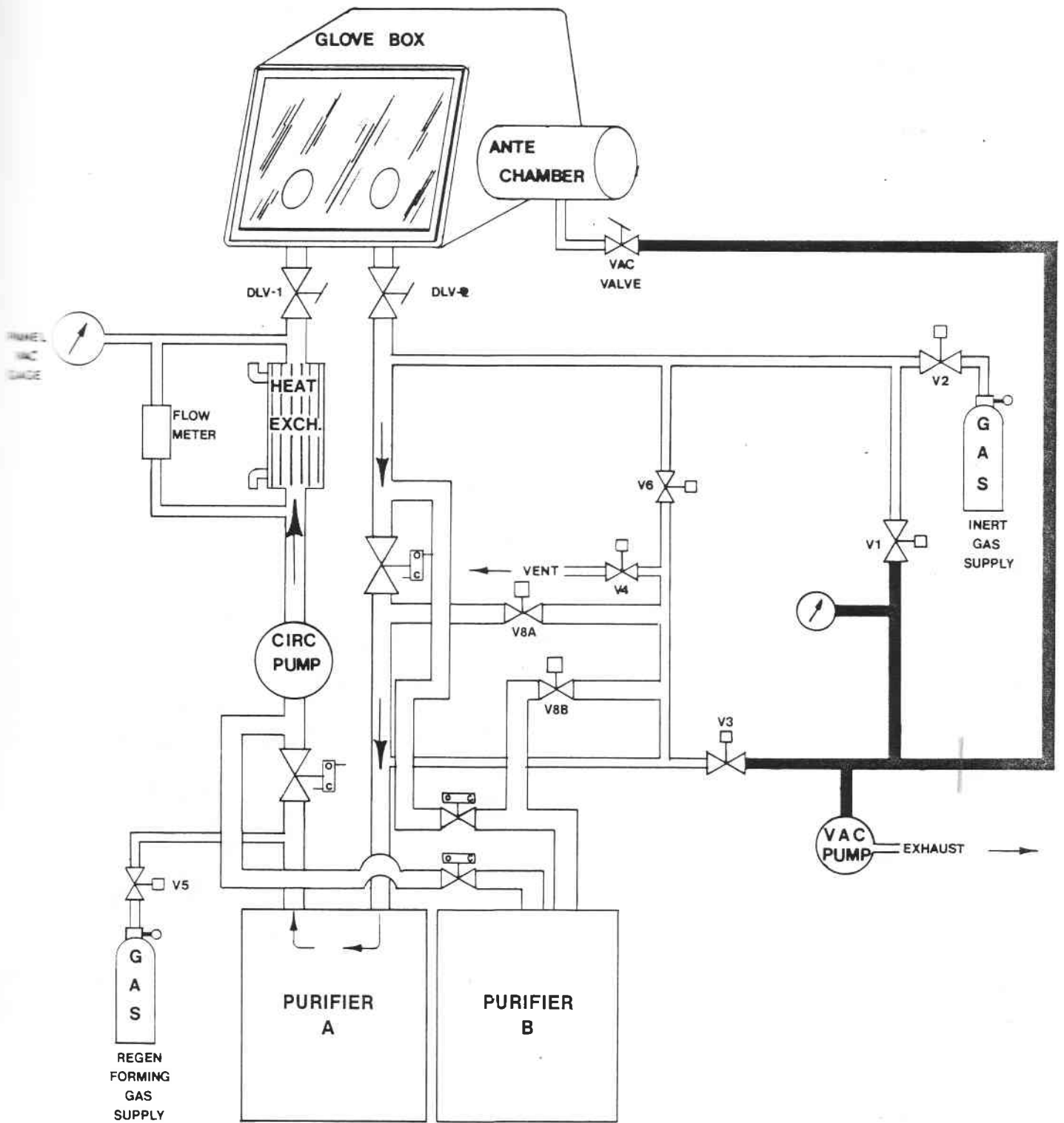

Figure 6-1. M040-2 Simplified System Diagram

M040-2-11/78

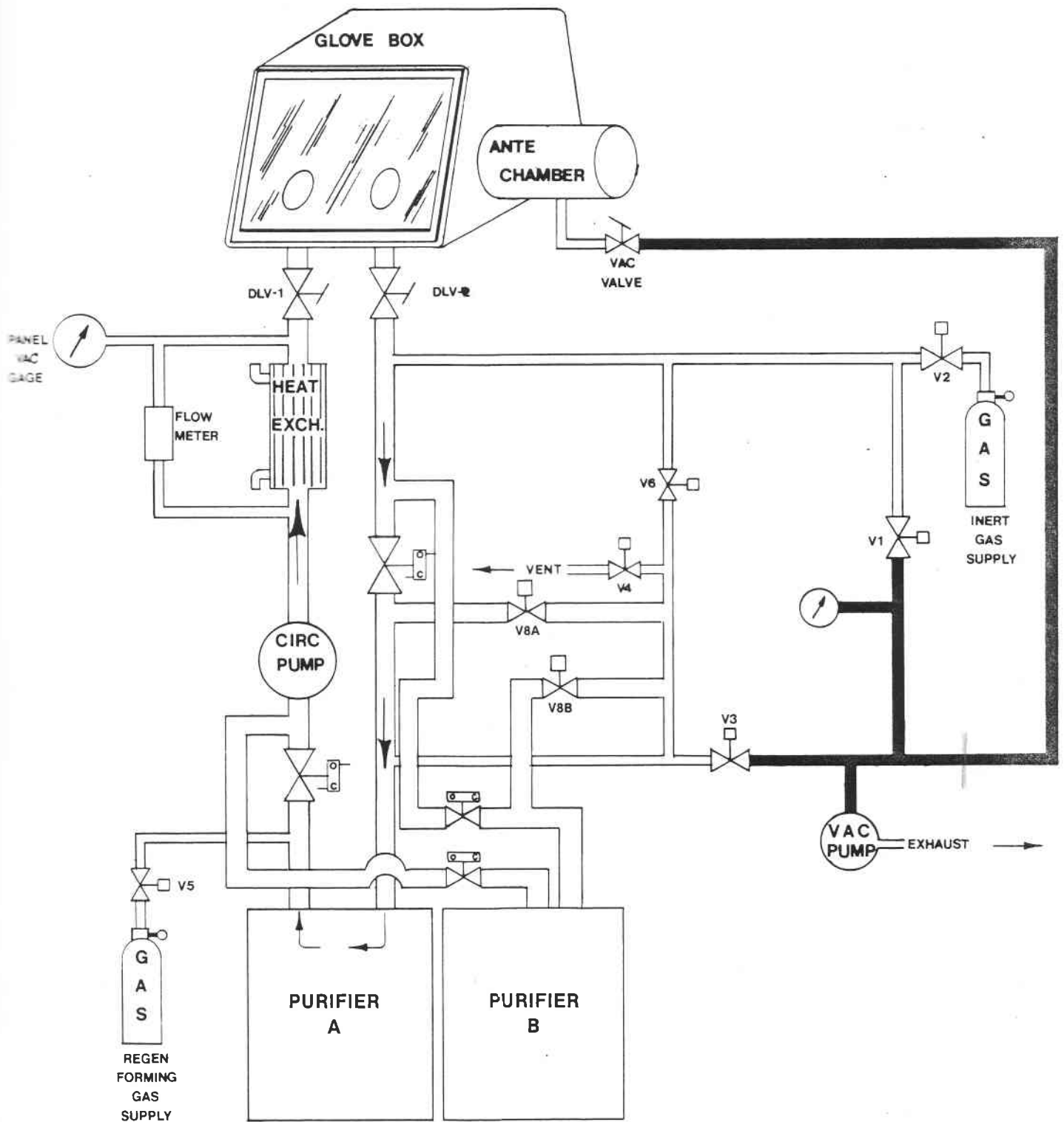
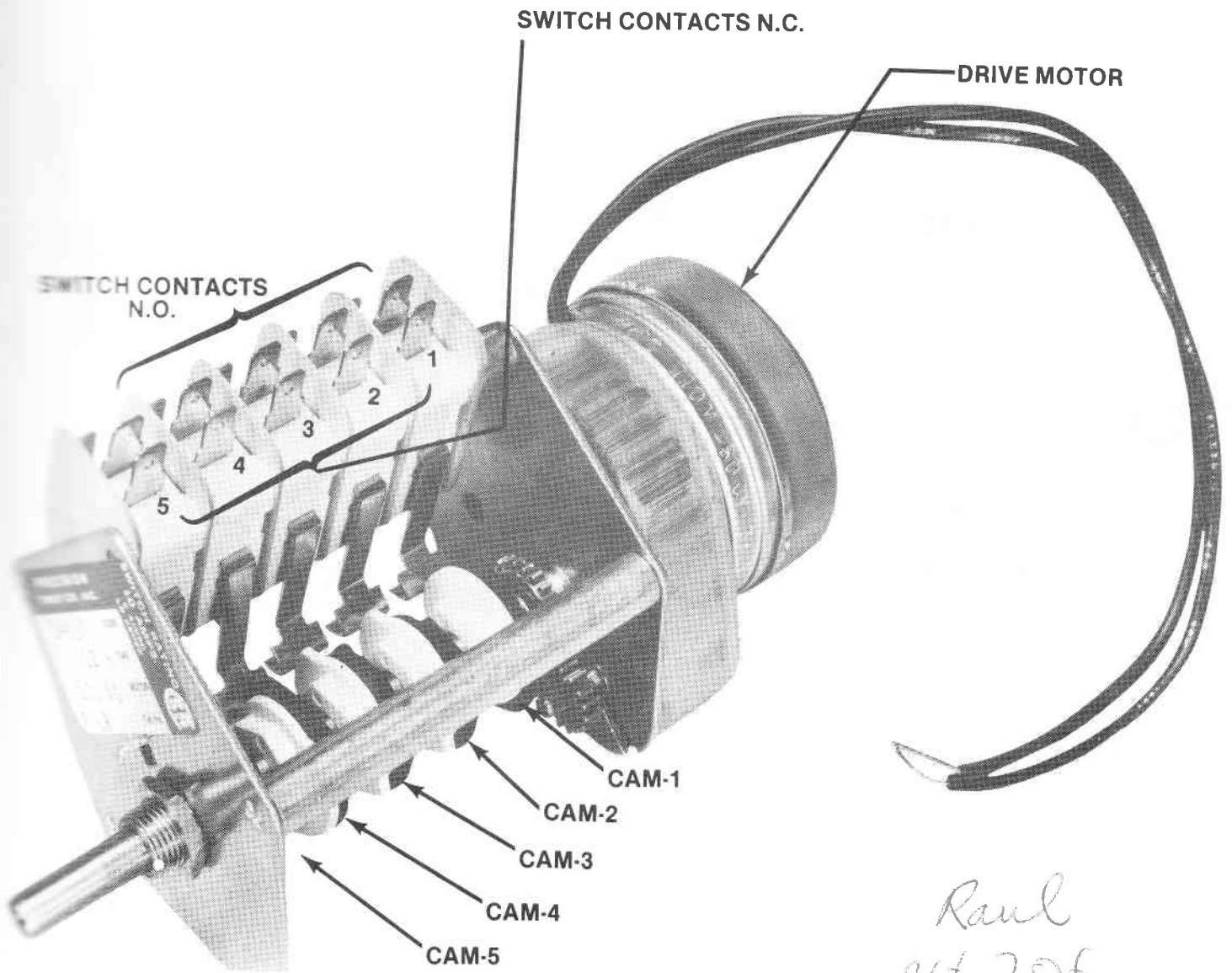

Figure 6-1. M040-2 Simplified System Diagram



*Raul  
ext. 206*

Figure 6-2. Regeneration Timer - Upper View

*\$20.75*

*1301-1 \$145 + shipping*

M040-2-11/78

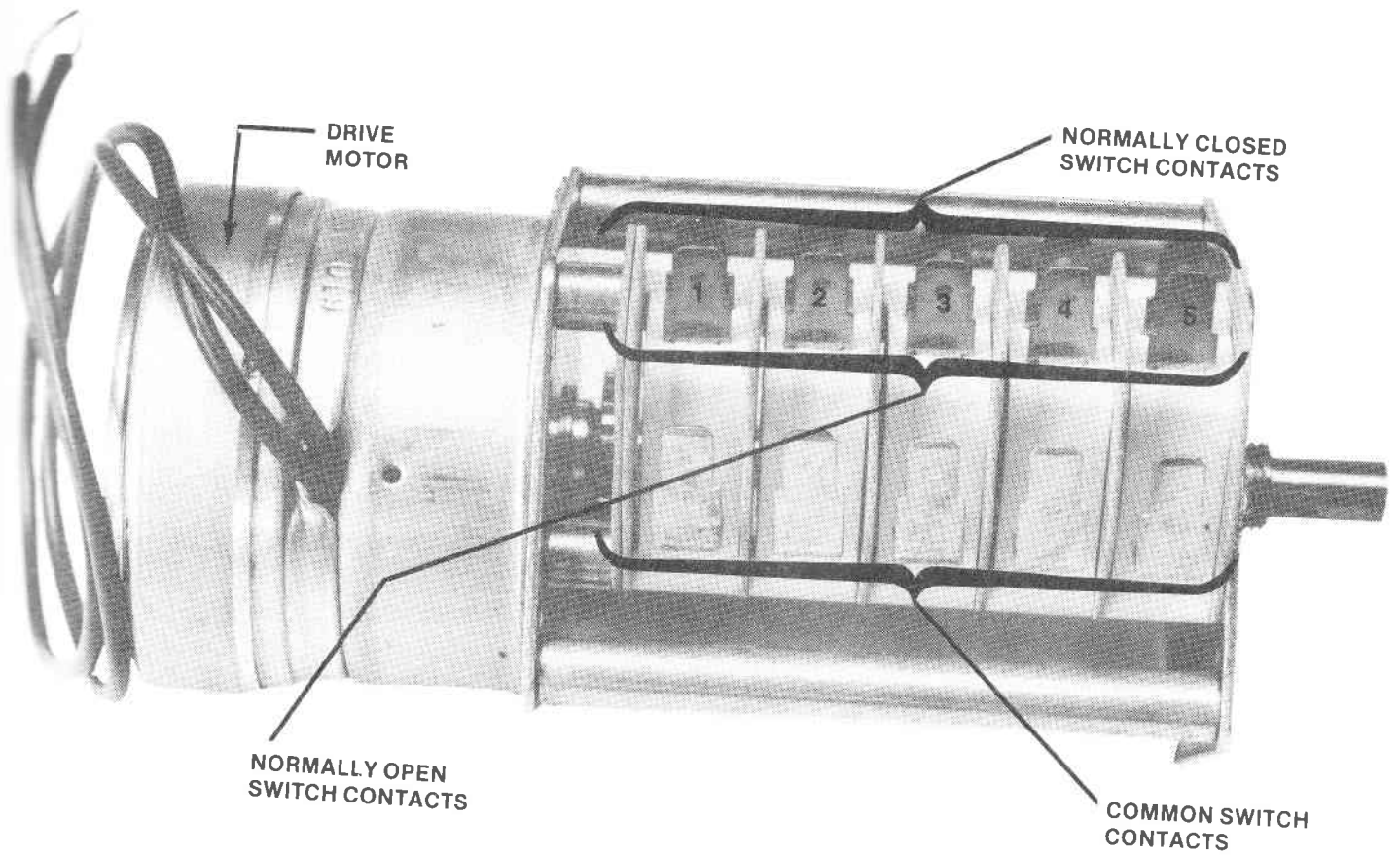

Figure 6-3. Regeneration Timer - Side View

7-0 MAINTENANCE7-1 GENERAL

Maintenance related to the M040 involves both "scheduled" and "non-scheduled" types of inspection and/or repair. These two categories are uncomplicated due to the relative simplicity of the M040 design and component selection.

7-2 PERIODIC MAINTENANCE/INSPECTIONS

"Periodic Maintenance" covers those operations which should be performed at regular intervals and which, if completed as suggested, will add measurably to the life of the M040.

Scheduled maintenance consists of the following:

- Inspection of, and replacement of, the oil in the vacuum pump.
- Inspection/replacement of any air filters installed in the main circulation system.
- Inspection of the heat exchanger and the water cooling lines; to verify proper water temperature and flow rate.

7-3 NON-SCHEDULED MAINTENANCE

Non-scheduled maintenance could include the following items:

- Leak testing of the system or a component.
- Replacing the vacuum pump oil.
- Replacing the heat exchanger.
- Inspecting all hardware, connections, etc.

7-4 VACUUM PUMP

The oil in the vacuum pump should be replaced:

- After 100 hours of operation after initial installation.
- Every three months thereafter.
- Whenever oil level is below oil level line in sight glass.

A manufacturer's instruction sheet for the type of vacuum pump supplied, is furnished as a part of each technical manual shipped with all DRI-TRAINS.

7-5 CIRCULATION FILTERS

The DRI-TRAIN does not contain filters in the circulation lines. DRI-LABS and VAC-LABS do contain air circulation filters.

The circulation filters must be replaced when/if they will not permit normal free-flow of gas through the system. The pressure drop across "in-line" filters must never exceed 1" of water column.

7-6 HEAT EXCHANGER

If the water flow through the heat exchanger becomes restricted due to material or dirt depositing inside, the heat exchanger must be replaced. No special instructions or precautions are applicable. After replacing the exchanger, check to see that the water flows freely at a rate of at least 1 gpm.

Note the flow-meter reading before and after replacing the heat exchanger, and after the new exchanger is installed, the flow rate should have returned to normal.

7-7 LINES AND CONNECTIONS

Periodically - or at recommended three month intervals - inspect all valves, fittings, lines, tubing and electrical connections for general mechanical, pneumatic, electrical integrity.

7-8 AIR VALVES (V12A, V12B, V13A, V13B)

If the air-power cylinders which operate these valves remain unused - are not cycled for a long period of time, they may become stiff due to coagulation of the lubricant on the seals; and they may not operate.

If this condition arises, remove the cylinders, disassemble and clean them.

This condition may be avoided by cycling the valves periodically (such as weekly), using the PURIFIER switch to alternately select REGENERATE A/CIRCULATE B or REGENERATE B/CIRCULATE A.

7-9 LEAK TESTING

The first choice of a method of leak detection is to connect a Helium detector into the DRI-TRAIN circulation system. The system is then totally evacuated and Helium is sprayed on each joint and component. Any leak - even extremely small ones - will be detected by this method.

The M040 does not have a set place to connect a helium detector. For that reason no detailed procedure for this type of leak check is given here.

If the above method must be used, consult Vacuum Atmospheres Company directly.

#### 7-10 LEAK TESTING-HELIUM SNIFFER

This method employs a Helium Mass Spectrometer with a sniffer probe, and is independent of the type of sniffer equipment used.

The details are described in Section-6 of this manual. Appropriate warnings are also given there concerning the use of this method of leak detection.

#### 7-11 LEAK TESTING-BUBBLE AND PRESSURE

This is perhaps the simplest and the quickest method, and is most often used as a preliminary or "first attempt" to locate a suspected leak. If it fails to expose the source of a suspected leak, then one of the more penetrating helium leak tests are required.

The procedure for performing a "pressure and bubbles" leak check is as follows:

#### **Note**

This procedure assumes the DRI-TRAIN to be connected to, and working with, a DRI-LAB for the sake of providing an example. Monitor system pressure during this procedure using the compound pressure gage inside the console.



7-12

STEPS

- a. Position these valves and switches as follows:
  - DRI-LAB inlet and outlet valves closed.
  - DRI-TRAIN power OFF.
  - PEDATROL power OFF.
  - Purifier switch to CIRCULATE A or CIRCULATE B.
- b. Depress and hold the R-side of the foot switch. Allow the pressure to build up to - BUT NOT EXCEED - 4 psi.
- c. Periodically tap the R-side of the foot switch - as required - to stabilize the pressure in the entire system.
- d. Apply a soapy water solution to all joints, valves, seams, etc.  
  
Do not soap the vacuum manifold and its joints.
- e. Monitor the compound pressure gage throughout this period. Any drop in pressure while the system is in this mode, will indicate or verify the presence of a leak.
- f. A leak will be evidenced by the formation of a bubble or bubbles at the point of the leak.
- g. After the leak has been eliminated, restore the system to normal operation.
- h. If no leak was discovered, relieve the system pressure using the L-side of the foot switch until it reads zero (ambient) pressure. Open the DRI-LAB inlet and outlet valves. Then turn the Pedatrol power ON.

M040-2-11/78

**CAUTION**

Do not use any type of Halogen leak detection equipment. Damage to the system will result. Halogen gases may permanently damage the Ridox.

7-13 CHEMICAL CHARGE-REPLACEMENT7-14 REPLACEMENT

The chemicals - Ridox and molecular sieve - last indefinitely unless they become contaminated as a direct result of certain contaminants being introduced into the circulation system.

These are listed in Section-4 of this manual, and the warnings presented should be read, understood, and heeded, by all who are involved in the use of the DRI-TRAIN systems.

7-15 PROCEDURE

1. Turn-off (disconnect) all electrical power to the DRI-TRAIN.
2. Disconnect - turn off - all gas, air and water utilities.
3. Remove the front and rear blank panels for full access.
4. Remove the air-actuators from the valves on the applicable purifier.
5. Disconnect this purifier's heater cable from the inside electrical panels.
6. Remove the applicable air-valves: carefully.
7. Disconnect the two 3/8" gas lines at the purifier.

8. Move the purifier canister out of the cabinet.
9. Dump the old chemicals out of the applicable purifier through the ports in the top of the unit.

(Use of a shop-type vacuum might simplify the task.)

**WARNING**

PROTECTIVE MASKS, CLOTHING, ETC., MAY BE REQUIRED WHEN HANDLING AND/OR BREATHING THE FUMES OF THE CONTAMINATED CHEMICALS. THE NATURE AND EXTENT OF PROTECTION REQUIRED IS DEPENDENT ON THE NATURE OF THE SUSPECTED - OR CONFIRMED - CONTAMINANTS PRESENT IN THE EXPENDED CHEMICALS.

THE DETERMINATION OF THE TYPE AND EXTENT OF THE PRECAUTIONS REQUIRED IS THE SOLE RESPONSIBILITY OF THE USER.

WHEN IN DOUBT, CONTACT VACUUM ATMOSPHERES COMPANY DIRECTLY.

10. To replace the contaminated chemicals with new ones, proceed as follows:
  - Pour in 8 lbs of molecular sieve.
  - Add 10 lbs of Ridox.
  - Add another 8 lbs of molecular sieve.

**Note**

The chemicals (Ridox and molecular sieve) are in granular or pebble form. They may be added to the purifier through the OUTLET port on the top of the canister. Refer to Figure 5-3.

11. Place the purifier being repaired back into its cavity in the cabinet.

Clean and lubricate (Use VAC LUB) the two air-valves prior to reinstallation.

12. Reinstall the air-valves.
  - Do not force the valves. They should fit in place securely and easily.
  - Tighten the three bolts and their nuts securely.
  - Mount the air-cylinder brackets on the valves. Take care in the alignment of the coupling on the shafts. The shaft protrusion on the front of the air-cylinder may be turned slightly back and forth, to check for good alignment and freedom from binding.
  - Secure the mounting flanges. (See Figure 8-15)
13. Reconnect the two 3/8" lines.
14. Plug-in the electrical cord from the purifier's heater.
15. Carry out all related steps required to perform an Initial Regeneration and establish an inert atmosphere in the system. These procedures are covered in Section-3 of this manual.

8-0 PARTS8-1 REPLACEMENT POLICY

Vacuum Atmospheres Company warrants all parts in the DRI-TRAIN. This means that all parts or assemblies installed in the M040-2, whether or not they are built by VAC, are guaranteed in accordance with the WARRANTY at the beginning of the manual.

8-2 REWORKED PARTS

Most parts purchased by VAC for use in the M040-2 are reworked at the factory in various necessary ways to make them leak free under light gas conditions such as those which are common to DRI-TRAIN applications.

Most valves used by VAC are reworked and fitted with special "O-rings."

8-3 CIRCULATOR

The CIRCULATOR (also referred to as circulation blower or simply blower) is covered by an exchange policy through Vacuum Atmospheres Company.

8-4 VACUUM PUMP

The vacuum pump in the M040-2 is pre-drilled to fit the mountings in the console.

This pump is also covered under the exchange policy.

8-5 PHOTOHELIC

The Photohelic is also covered under the exchange policy.

8-5 ORDERING PROCEDURES

To order spare or replacement parts, contact Vacuum Atmospheres Company directly, by phone or letter.

PHONE: (Area 213) 644-0251

WRITE:  
VACUUM ATMOSPHERES COMPANY  
4652 W. ROSECRANS AVENUE, P.O. BOX 1023  
HAWTHORNE, CALIFORNIA 90250

8-7 PARTS LIST AND PHOTOS

8-8 GENERAL

Photographic displays (Figures 8-1 through 8-16) are presented in this section to identify all M040-2 parts. Each part in the photos is tagged with a circled number.

The parts list (pages 8-3 and 8-4), provides the proper nomenclature, VAC ordering numbers, and a cross-reference to the photos in this section.

Table 8-1. Parts List - M040-2

ITEM	SYMBOL	DESCRIPTION	VAC NO.
1		Cabinet (M040-2H)	011512
2		Cabinet (M040-2V)	011495
3	1M	Vacuum Pump	7479
4	1B	Circulator Blower	3082
5		Heat Exchanger	5015
6	V12A, V13A, V12B, V13B	Pneumatic Actuator	7407
7	V12A, V13A, V12B, V13B	Pneumatic Valve	7416
8	1T	Transformer	7288
9		Purifier Assembly (A & B)	011471
10		Feedthru Plate	013497
11		Pedatrol Front Panel	011510
12	1PH	Pressure Switch-Photohelic	1208
13	V1 thru V6	Solenoid Valve	7404
14	2S, 4S	Switch, DPST ON-OFF	7411
15	V7	Double Solenoid Valve	7405
16	1CR	Relay	1037
17	2T	Transformer	1275
18	1C	Capacitor	1298
19	1J, 2J, 3J	Flanged Outlets	7397

Table 8-1 (continued)

ITEM	SYMBOL	DESCRIPTION	VAC NO.
20	1S	DPST Switch ON-OFF	7408
21	3S	4PST Switch ON-NONE-ON	7410
22	1FS	Foot Switch	1122
23	1TM	Timer-Regeneration	1301-1
24	1LT	Light-Amber (110 vac)	1263
25	2LT	Light-Red (110 vac)	7395
26	3F, 4F	Fuse-2 amp	1253-13
27	1F, 2F	Fuse-15 amp	1253-14
28	5F, 6F	Fuse-5 amp	1253-12
29		Electrical Outlet Assembly	1146
30		Vacuum Gage-0-30	7398
31		Fuse Holder	7390
32	V1-V6	Coil-Solenoid Valve	7404-1
33	V7	Coil-Solenoid Valve	7405-1
34	V8A, V8B	Coil-Solenoid Valve	7404-1
35		Flow Indicator	7399
36		Knob-Timer (Regeneration Timer)	7403
37		Pressure Gage-Compound	2600



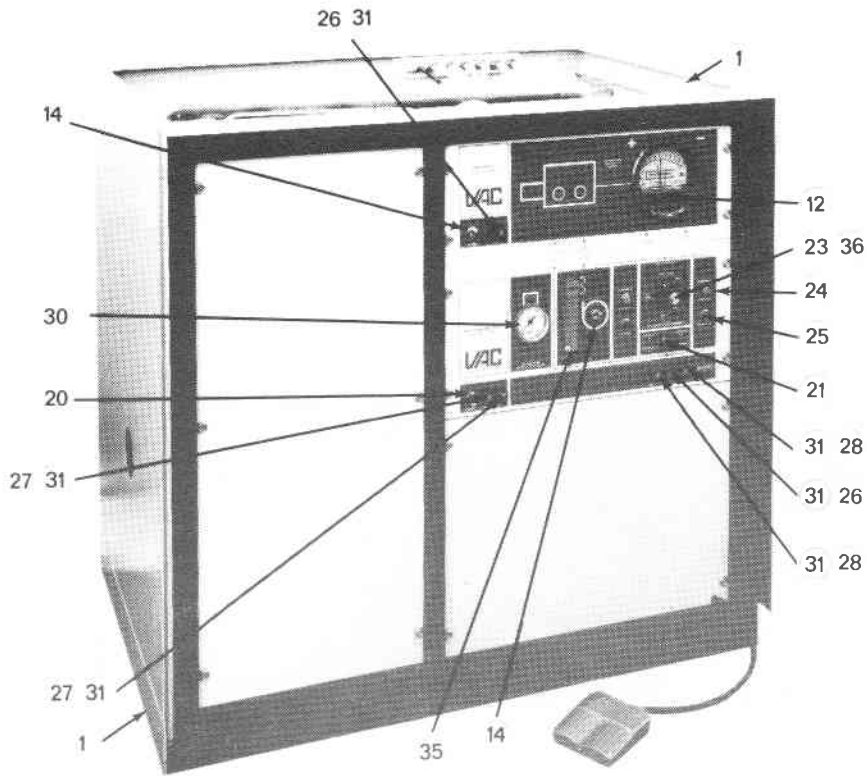

Figure 8-1. M040-2H Front View

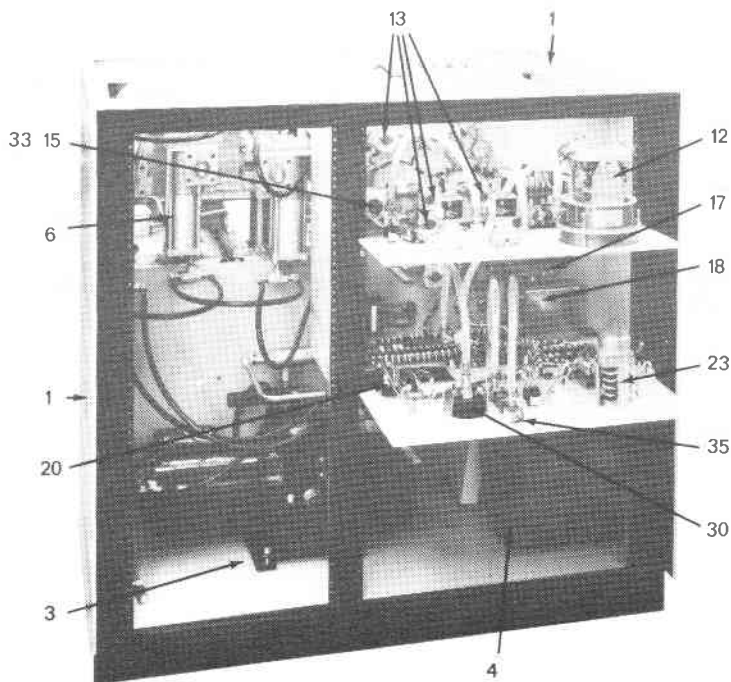

Figure 8-2. M040-2H Front View - Panels Open

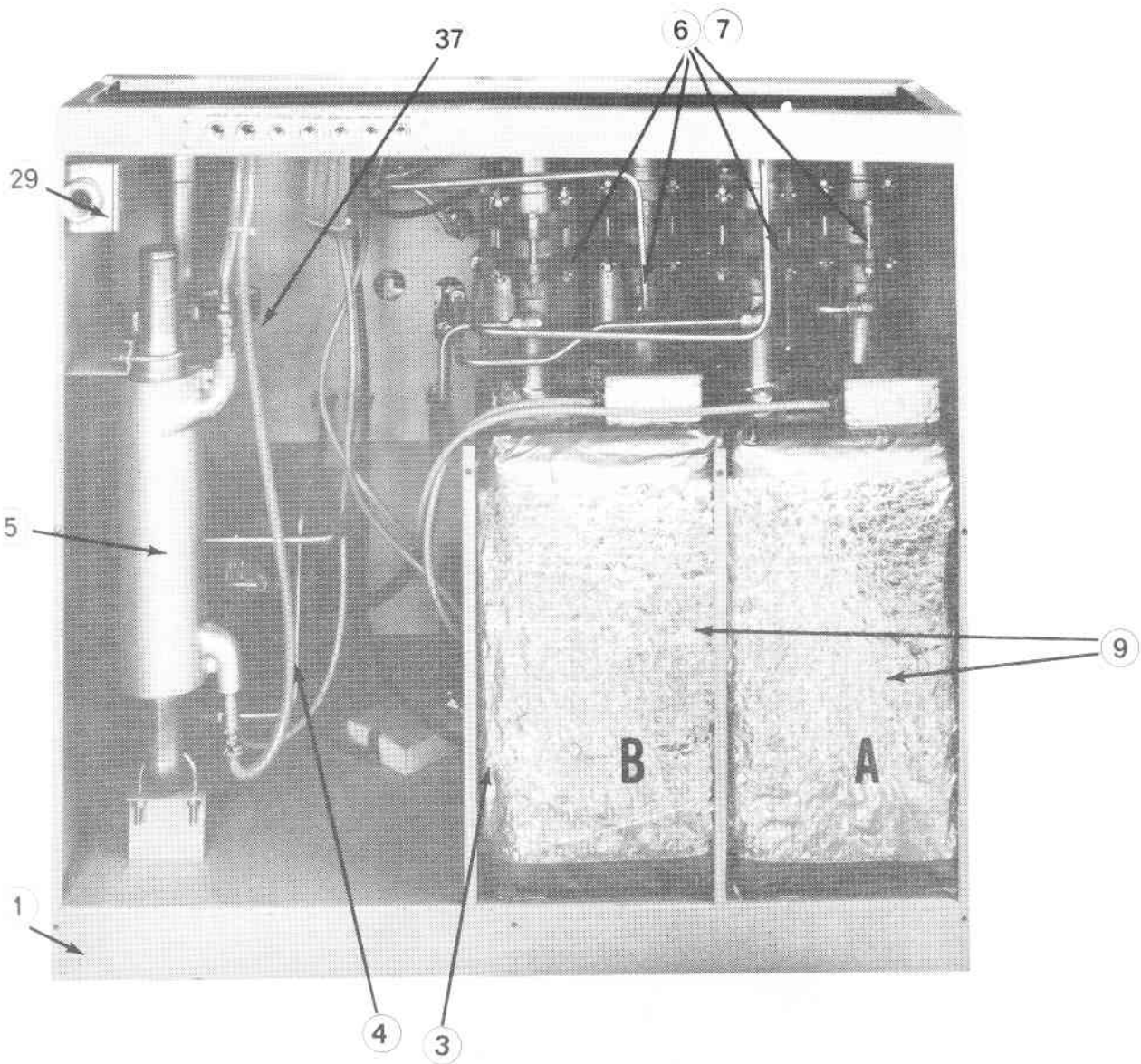

Figure 8-3. M040-2H Rear View

M040-2-11/78

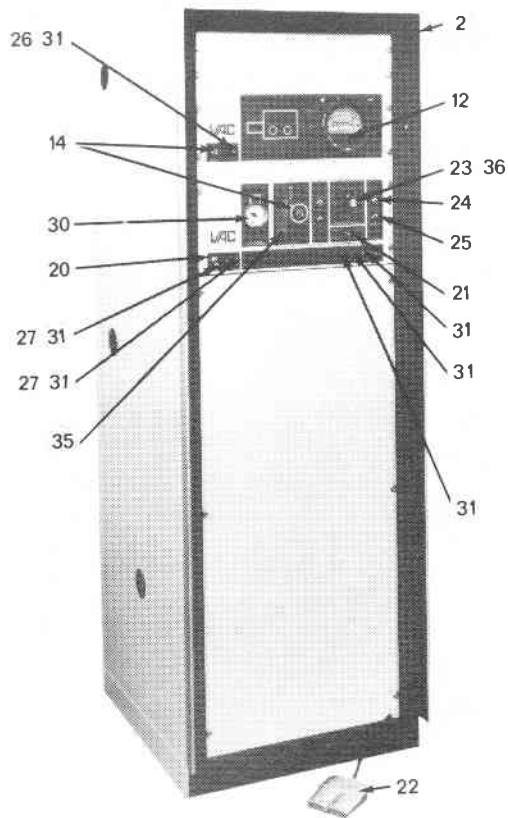

Figure 8-4. M040-2V Front View

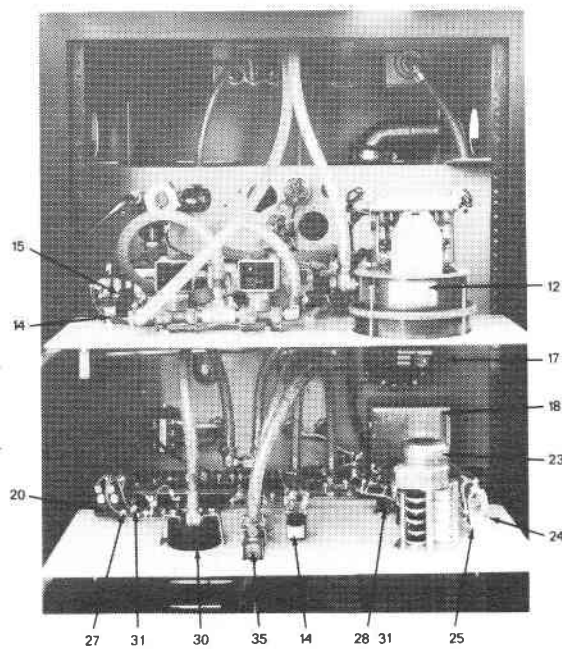

Figure 8-5. M040-2V Front View - Panels Open

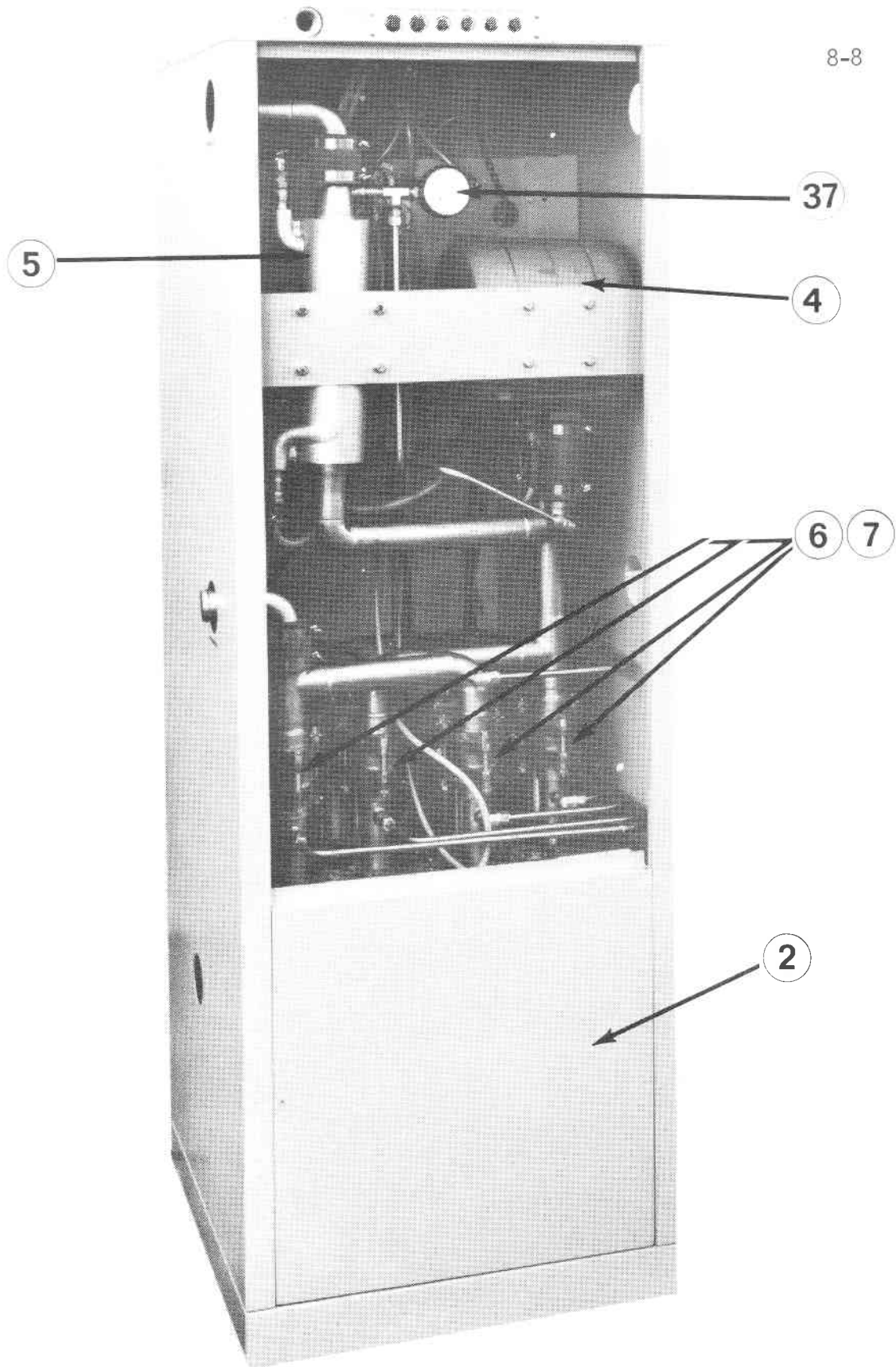

Figure 8-6. M040-2V Rear View

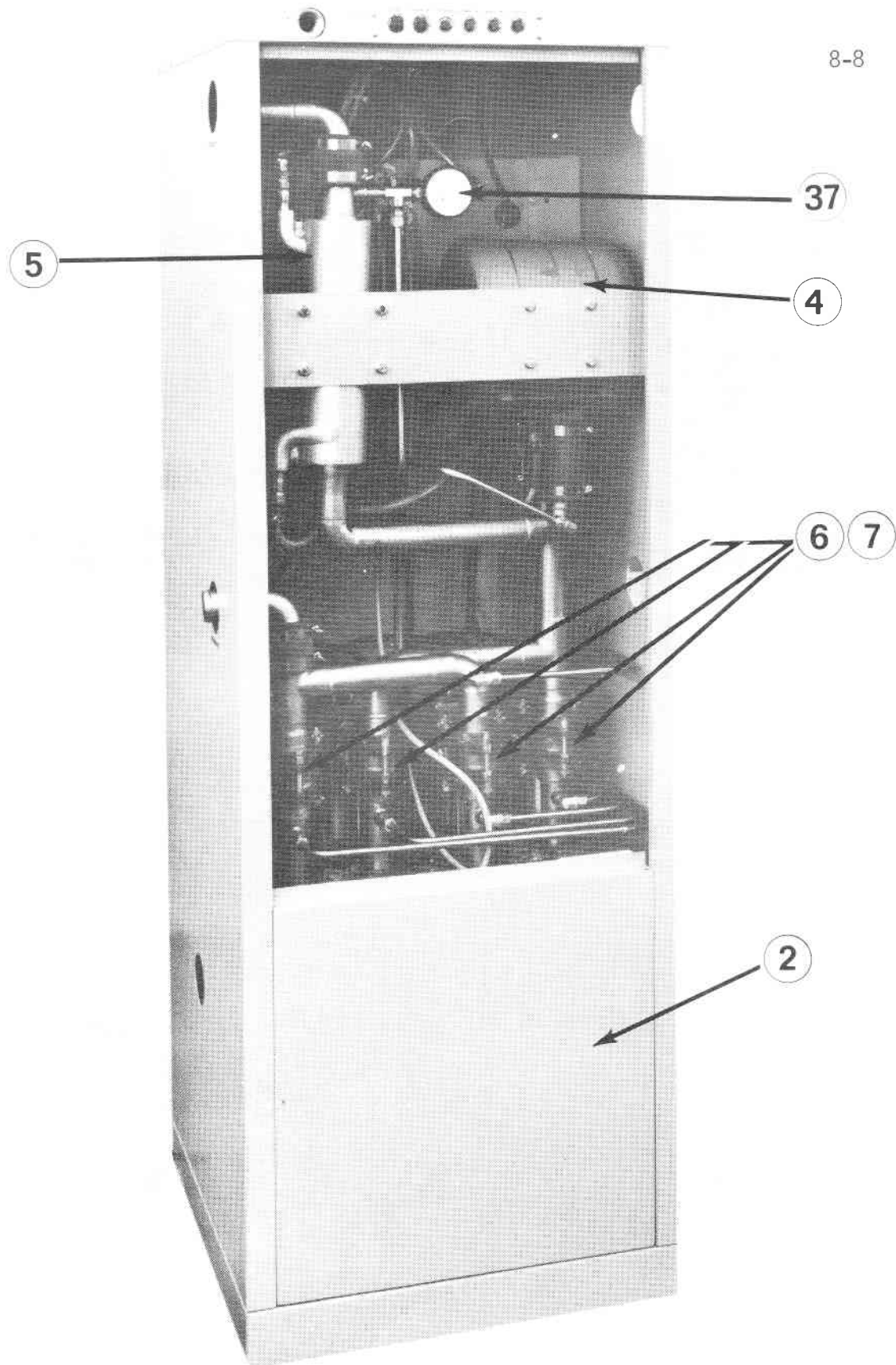

Figure 8-6. M040-2V Rear View

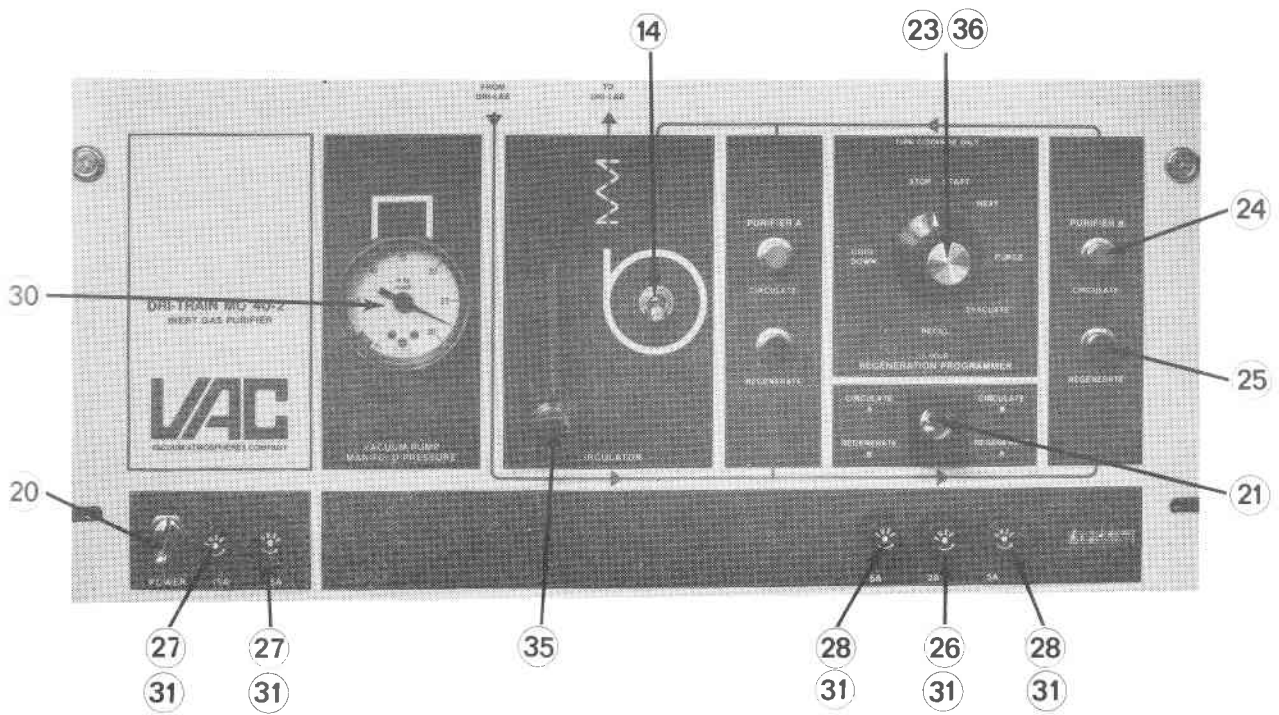

Figure 8-7. DRI-TRAIN Control Panel - Front View

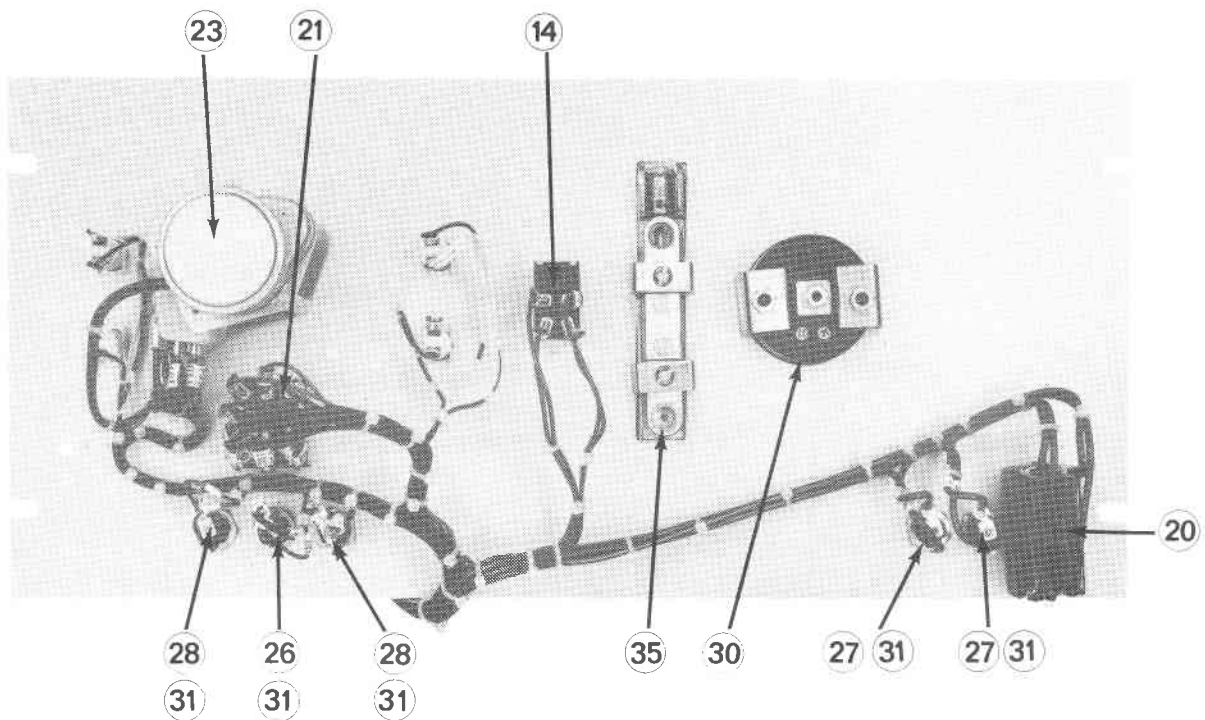

Figure 8-8. DRI-TRAIN Control Panel - Rear View



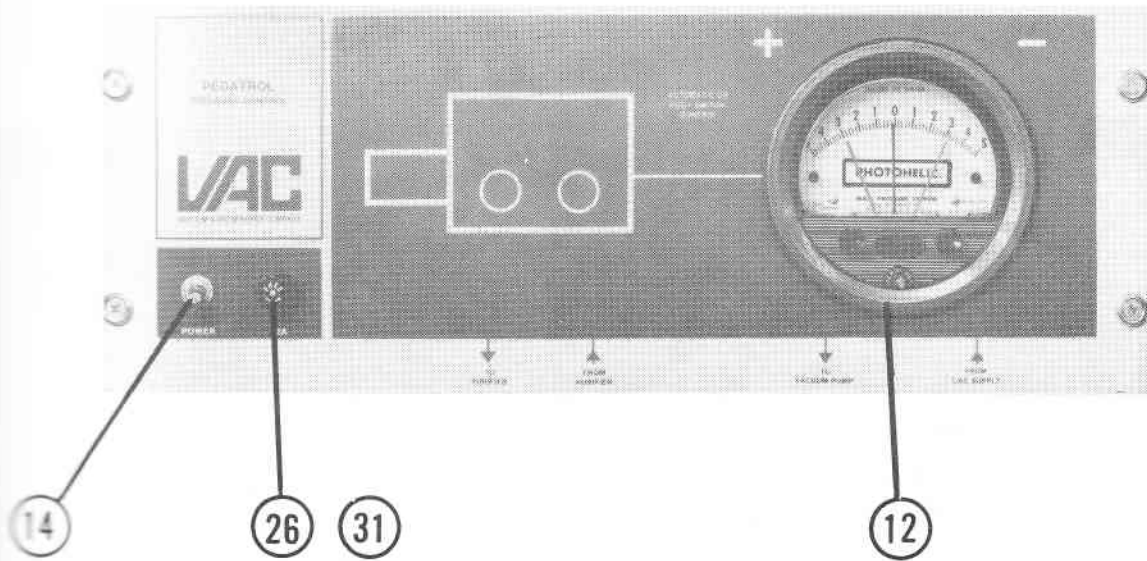

Figure 8-9. Pedatrol Panel - Front View

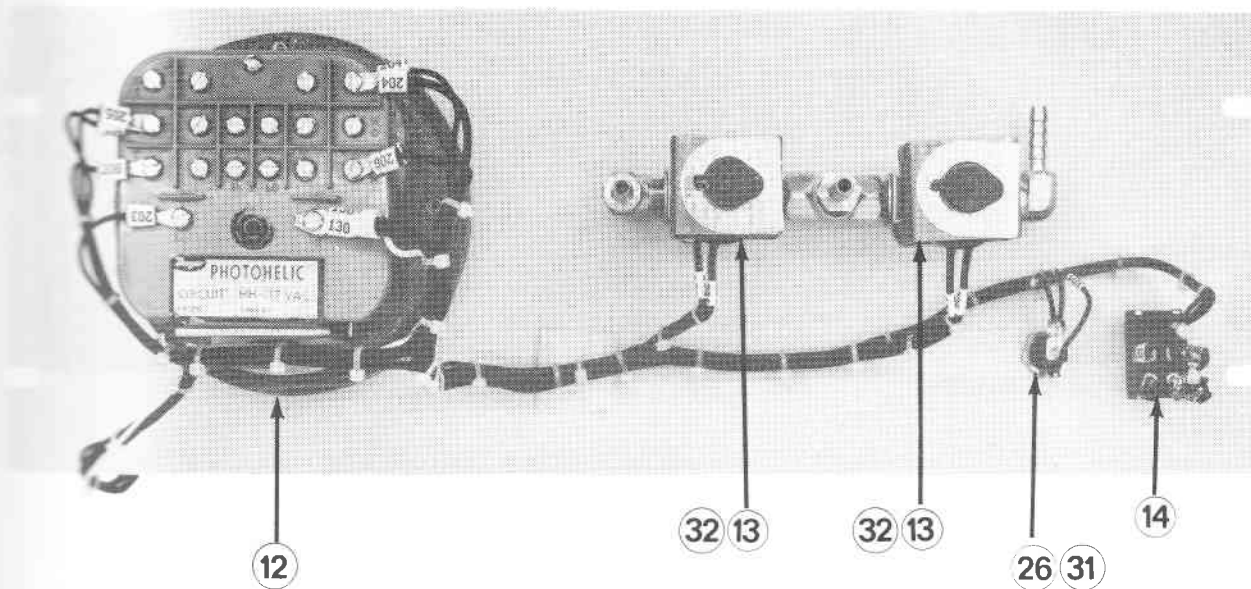

Figure 8-10. Pedatrol Panel - Rear View

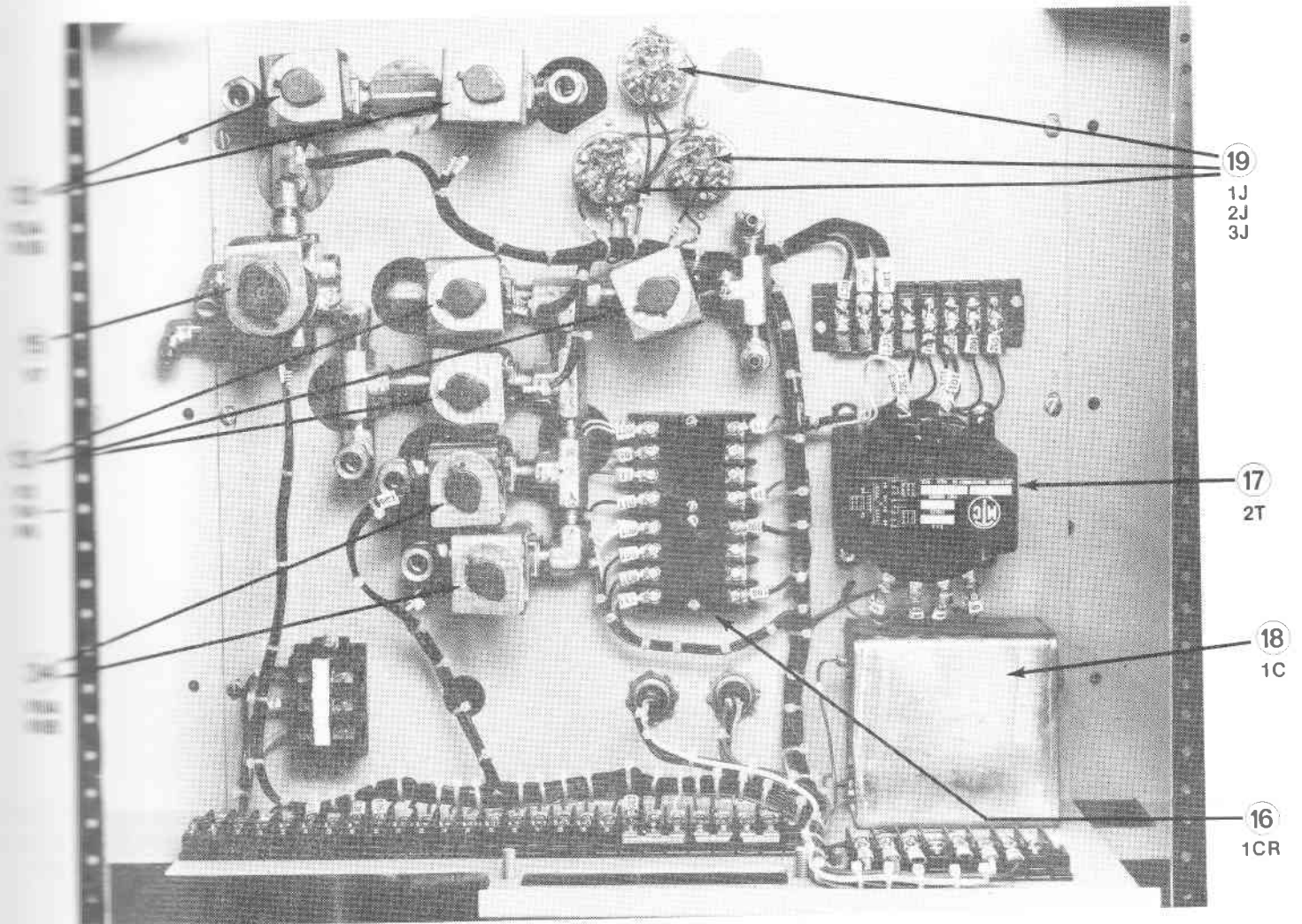

Figure 8-11. Electrical Sub-Assembly Panel



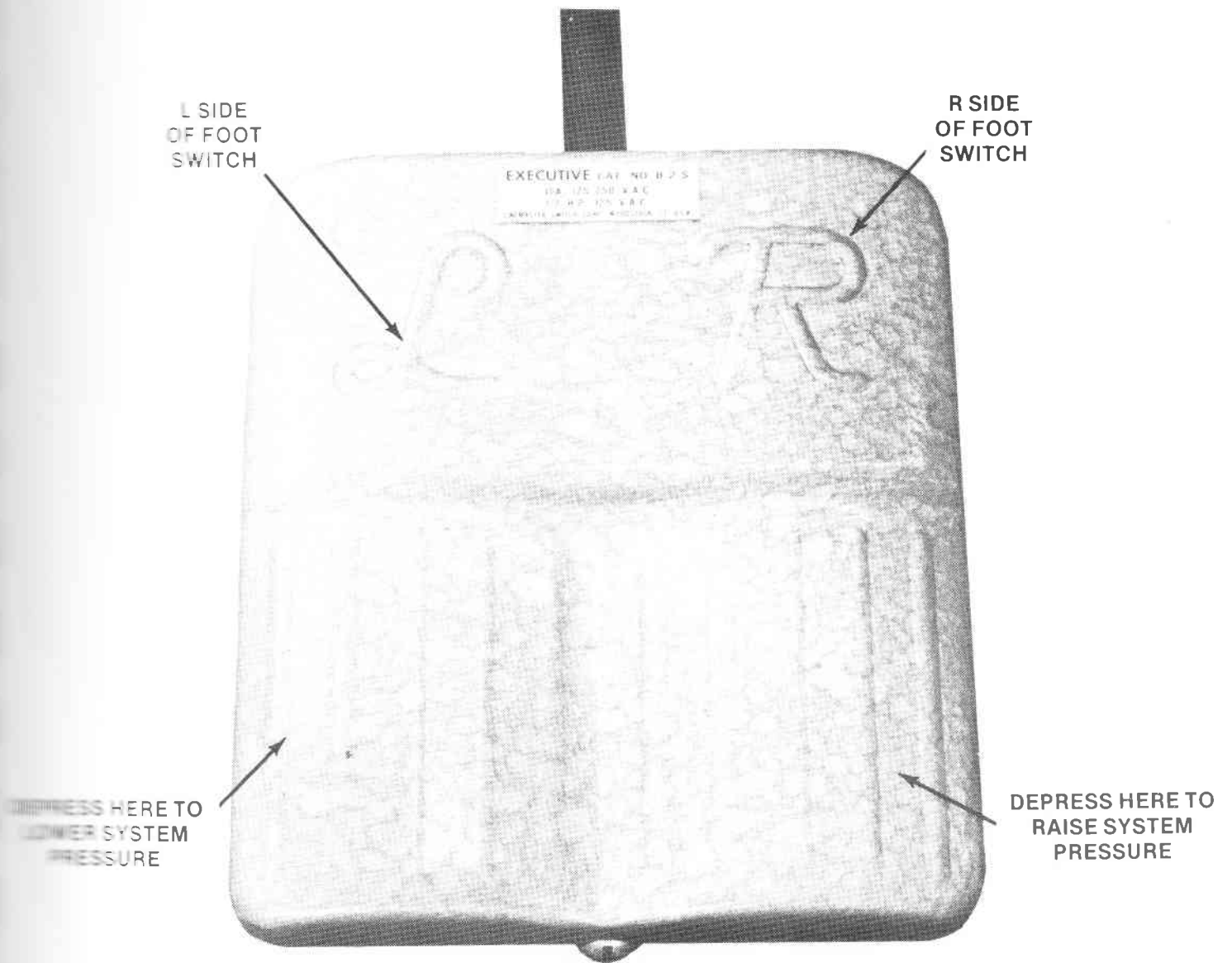
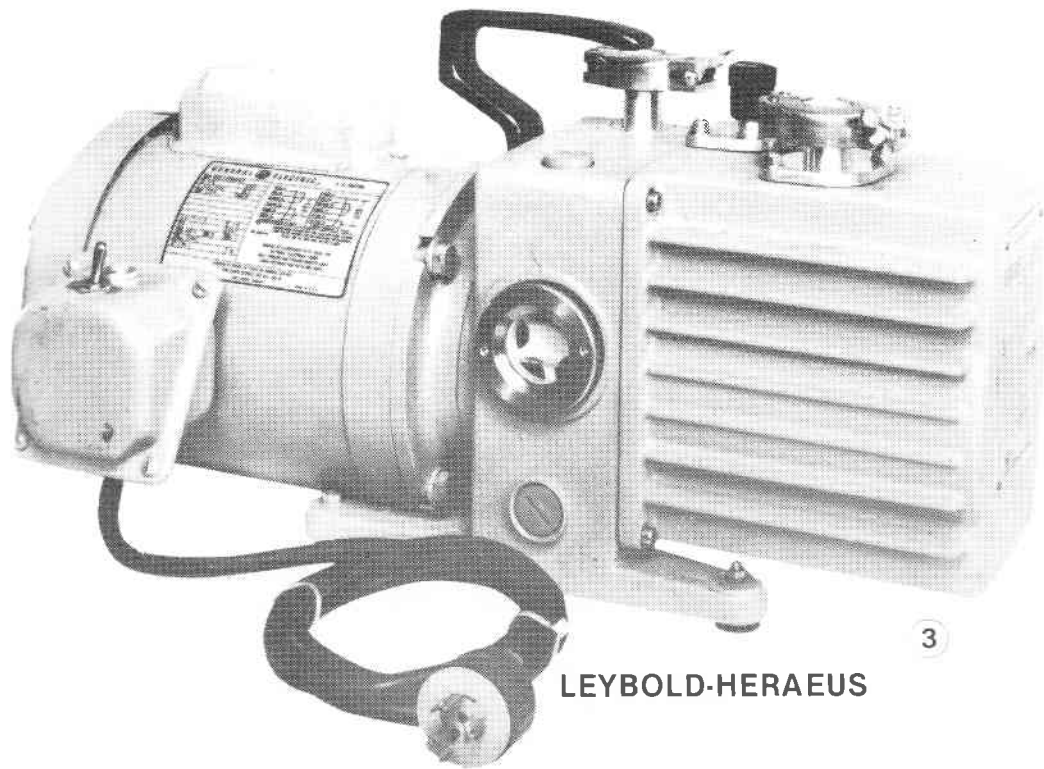

Figure 8-12. Foot Switch - Pedatrol



LEYBOLD-HERAEUS

Figure 8-13. Vacuum Pump - Leybold Heraeus

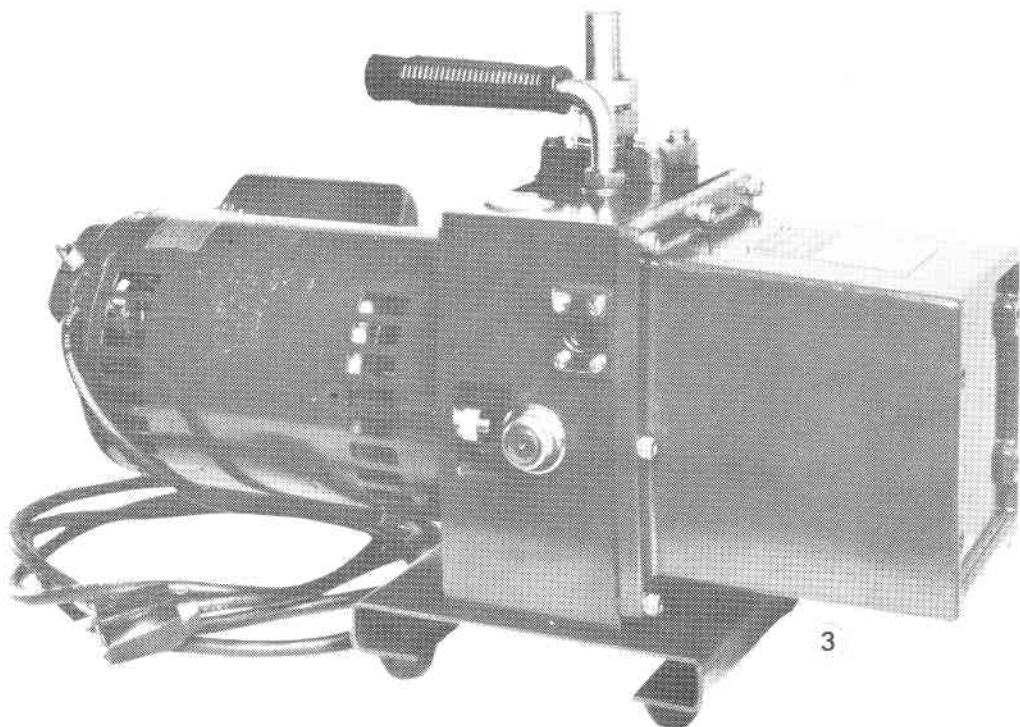

Figure 8-14. Vacuum Pump - Sargent Welch

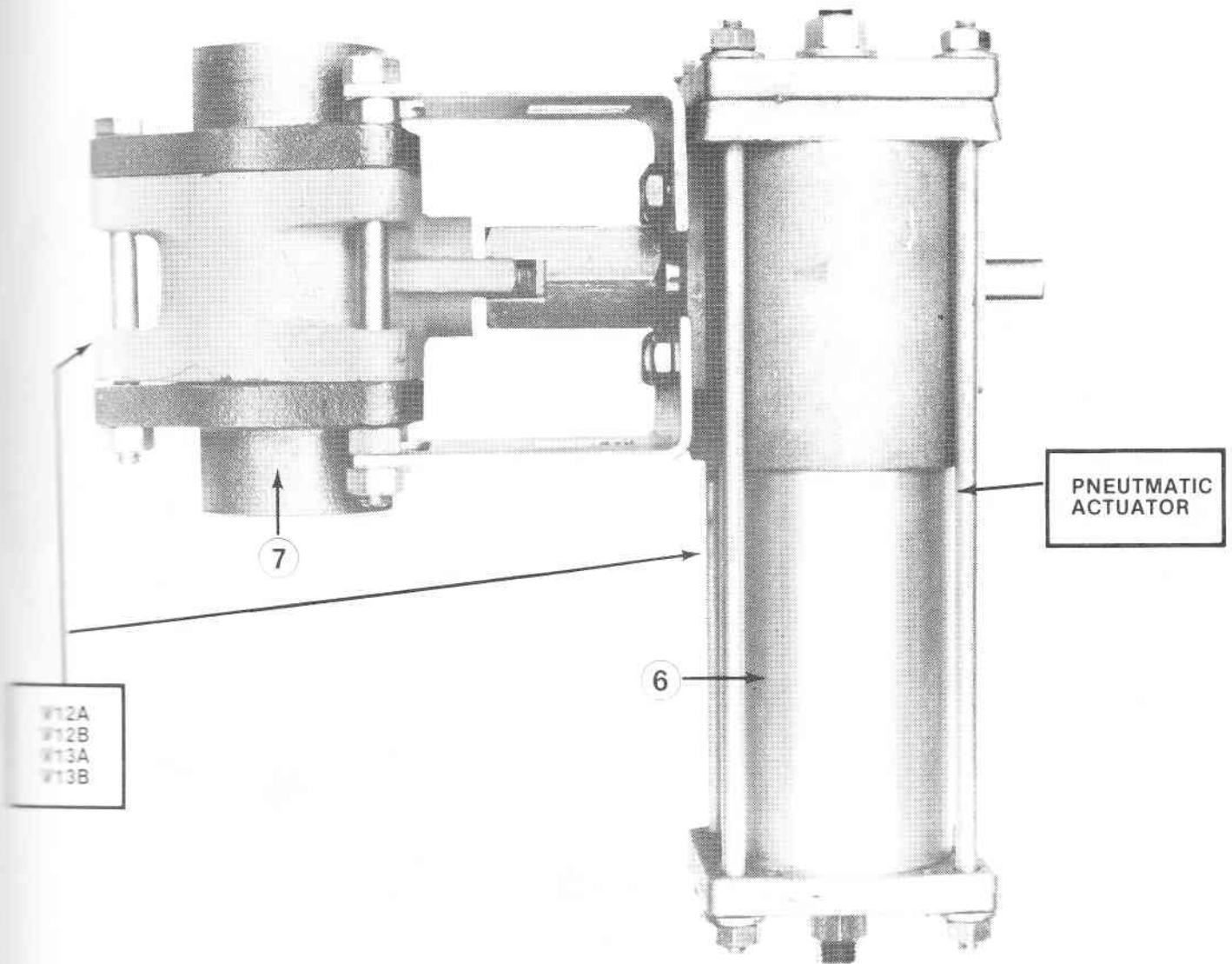

Figure 8-15. Pneumatic Actuator and Valve Assembly

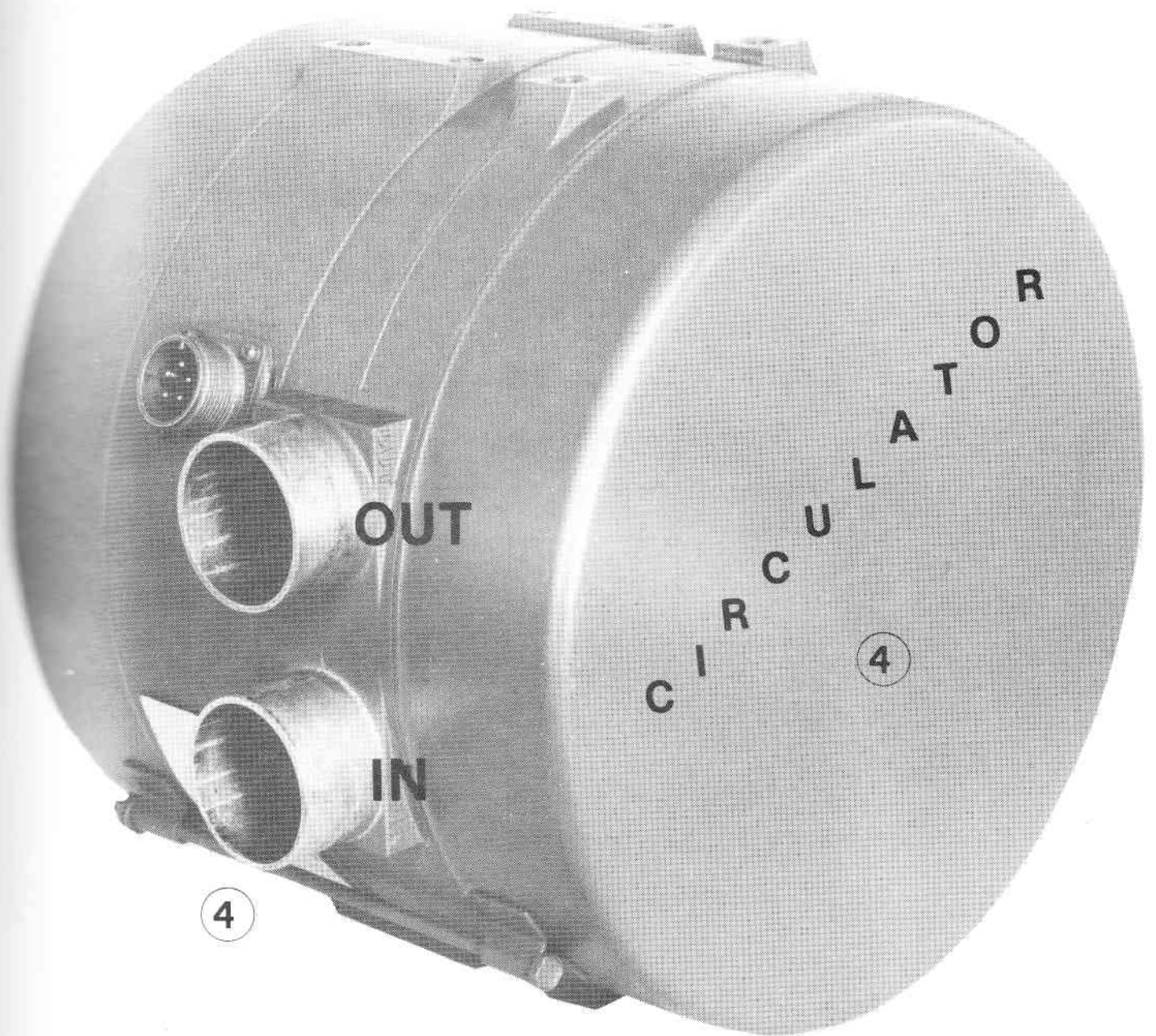

Figure 8-16. Circulator

INDEX	<u>PARA</u>	<u>TABLE</u>	<u>FIGURE</u>
Air Supply (Compressed Air) .....	2-9		
Applications .....	1-1		
Atmospheric Monitoring .....	2-12		
Blower (see Circulator)			
Circulator - Problems .....	6-3		
Circulator - Theory .....	5-36		
Circulation Gas Theory .....	5-10		
Circulation Rate .....	5-14		
Component List .....		5-1	
Compressed Air .....	2-9		
Contamination Warnings .....	4-1		
Controls and Indicators .....		4-1	
Chemicals (Purifier)			
Life Span .....	5-20		
Destruction-Warnings .....	4-1		
Daily Operations .....	4-6		
Dimensions .....		1-2	
Electrical-			
Initial Checkout Procedures - General ...	3-1		
Initial Checkout Procedures - Table .....		3-1	
Power Requirements - Table .....		2-1	
Power Requirements - General .....	2-3		

INDEX (continued)	<u>PARA</u>	<u>TABLE</u>	<u>FIGURE</u>
Flow Diagram .....			5-1
Flow Meter .....	4-7	...	4-1
Foot Switch - Operation .....	4-9		
Foot Switch - Theory .....	5-3		
Functional Description of the Sytem .....	1-2		
Fuses .....		4-1	
Gas-Connections .....	2-7		
Forming (See Regeneration)			
Inert (Make-up) .....	2-8		
Leak Testing .....	6-14		
.....	7-9		
.....	7-10		
.....	7-11		
Regeneration Forming .....	5-23		
Utilities .....	2-7	...	2-1
Heat Exchanger-			
Maintenance .....	7-6		
Water Requirements .....	2-11		
Installation-			
Connection Strip .....	2-8		
Gas Utilities .....	2-8	...	2-1
Initial Set Up-			
Electrical .....	3-1		
Establishing Inert Atmosphere .....	3-4		
Gas .....	3-4		



INDEX (continued)	<u>PARA</u>	<u>TABLE</u>	<u>FIGURE</u>
Operations-(cont.)			
Foot Switch .....	4-9		
Photohelic .....	4-8		
Regeneration .....	4-10		
Replacing Purifier Chemicals .....	7-13		
Utility Monitoring .....	4-7		
Oxygen Recovery-			
Rate Table .....			4-1
Theory .....	5-8		
Parts-			
Lists .....	8-7		
Ordering .....	8-6		
Replacement .....	8-1		
Pedatrol-			
Foot Switch .....	4-9		
Operation .....	4-8		
Troubleshooting .....	6-4		
Theory .....	4-1		
.....	4-6		
.....	4-8		
.....	4-9		
.....	5-1		
.....	5-3		
.....	5-4		
.....	5-5		
Performance Curves .....	4-4		4-1





INDEX (continued)	<u>PARA</u>	<u>TABLE</u>	<u>FIGURE</u>
Regeneration Programmer-Timer (cont.)			
Troubleshooting .....	6-7		
Cam-2 .....	5-31		
Cam-3 .....	5-32		
Cam-4 .....	5-33		
Cam-5 .....	5-34		
Schematic Diagram, Electrical .....	5-28		5-2
Theory of Operation .....	5-0 through 5-35		
Transformer Optional Wiring .....	2-4		
Troubleshooting-			
Air Operated Valves .....	6-6		
Circulator .....	6-3		
General .....	6-1		
Helium Leak Testing .....	6-14		
Photohelic .....	6-4		
Pressure Problems - Categories of .....	6-9		
Pressure Problems - General .....	6-8		
Regeneration Timer .....	6-7		
Solenoid Valves .....	6-5	6-1	
Vacuum Pump .....	6-2		
Utilities-			
General Requirements .....		2-1	
Compressed Air .....	2-9		

INDEX (continued)	<u>PARA</u>	<u>TABLE</u>	<u>FIGURE</u>
Utilities-(cont.)			
General Requirements .....		2-1	
Connections .....	2-7		
Electrical .....	2-3		
Gas .....	2-8		
Inert Gas Plumbing .....	2-13	... 2-1	..... 2-1,
Space Requirements .....	2-2		
Venting .....	2-10		
Water .....	2-11		
Venting-			
Purge Gas .....	2-10		
Vacuum Pump .....	2-10		
Water - Cooling Supply .....	2-11	... 2-1	
Water - Removal (from gas) .....	5-9		